

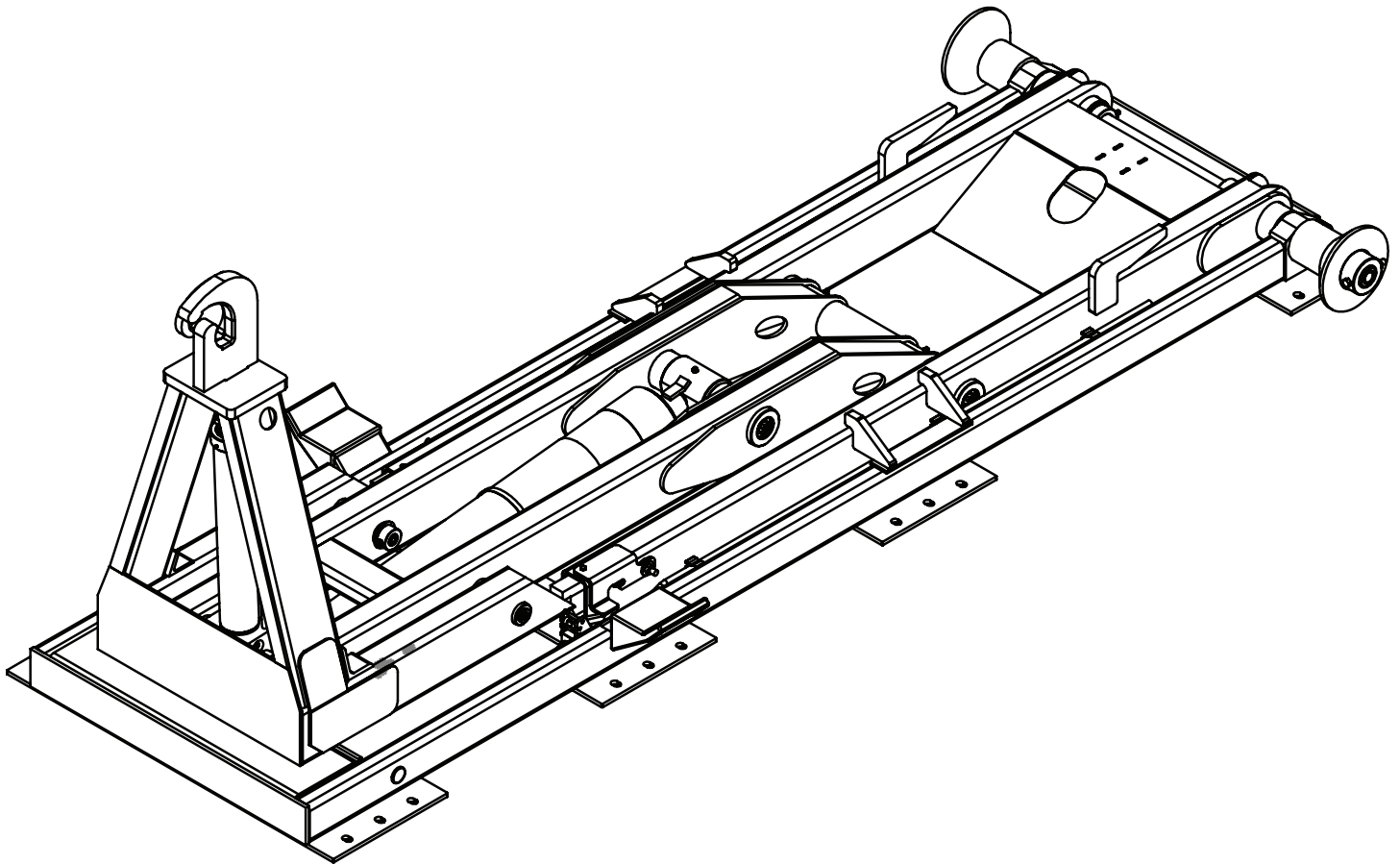

84-10 Flex Hooklift Owner's Manual

Installation • Assembly Drawings • Parts



Stellar Industries, Inc.

190 State Street

PO Box 169

Garner, IA 50438

800-321-3741

Fax: 641-923-2811

www.stellarindustries.com

Subject to Change without Notification.
© 2014 Stellar Industries, Inc.

Last Revision: 08/04/14

Table of Contents

Introduction.....	iv
Hooklift Nomenclature.....	v
Chapter 1 - Specifications.....	1
Model 84-10 Flex Specifications.....	1
Acceptable Subframe Dimensions - Model 84-10 Flex.....	2
Chapter 2 - Installation	3
General Installation.....	3
Installer Notice.....	3
Torque Data Chart.....	4
Installation Note	5
Step 1: Set the hooklift onto the truck frame.	5
Step 2: Bolt tie-down castings to mounting plates.....	6
Step 3: Drill mounting holes into frame rail.	7
Step 4: Bolt tie-down castings to truck frame.	7
Step 5: Install bumper.....	8
Step 6: Install taper tower (If applicable).....	9
Step 7: Install hydraulic reservoir and valve bank.	9
Step 8: Install PTO and pump.....	10
Face Seal/O-Ring Size Chart.....	11
Step 9: Route hydraulic hoses.....	11
Hose Kit - PN 72354.....	12
Power Beyond VDM8 Valve.....	13
Optional - Port Side Relief Installation.....	14
Step 10: Route Electrical Components.....	15
Step 11: Install cab and PTO controls.	16
Step 12: Install mud flaps and fenders.	17
Step 13: Install Hoist Up Light Sensor - PN 31806.....	17
Step 14: Apply Decals.....	18
Step 15: Fill reservoir and activate hydraulic flow.	19
Step 16: Operate hooklift.	19
Pressure vs. Capacity	19
Set System Relief Pressure	20
Chapter 3 - Assembly Drawings	21
Base Assembly - PN 41826	21
Dump Assembly - PN 33339.....	22
Secondary Assembly - PN 33341	23
Main Cylinder Assembly - PN 33404	26
Tilt Cylinder Assembly - PN 23460.....	27
25 Gallon Reservoir Assembly - PN 35883	28
Valve Bank Parts Drawing.....	29

Introduction

A copy of this manual is provided with every hooklift and can be found in the hard plastic manual case that is installed on the chassis. A copy of this manual shall remain with the hooklift at all times.

Throughout the manual, three signal words will be used to bring attention to important items:

NOTICE

A NOTICE signal word indicates a practice not related to physical injury.

⚠ WARNING

A WARNING signal word indicates a hazardous situation which, if not avoided, could result in death or serious injury.

⚠ DANGER

A DANGER signal word indicates a hazardous situation which, if not avoided, will result in death or serious injury.

Information contained within this manual does not cover operation, maintenance, or troubleshooting. Please refer to the General Shuttle Hooklift Manual for details on these items.

This manual is not binding. Stellar Industries, Inc. reserves the right to change, at any time, any or all of the items, components, and parts deemed necessary for product improvement or commercial/production purposes. This right is kept with no requirement or obligation for immediate mandatory updating of this manual.

In closing:

If more information is required or technical assistance is needed, or if you feel that any part of this manual is unclear or incorrect, please contact the Stellar Customer Service Department by phone at 800-321-3741 or email at service@stellarindustries.com.

**For Technical Questions, Information, Parts, or Warranty, Call Toll-Free at
800-321-3741**

Hours: Monday - Friday, 8:00 a.m. - 5:00 p.m. CST

Or email at the following addresses:

Technical Questions, and Information

service@stellarindustries.com

Order Parts

parts@stellarindustries.com

Warranty Information

warranty@stellarindustries.com

Hooklift Nomenclature

The Stellar® Shuttle is a hydraulic, body-loading device when mounted on a truck chassis. It can handle a multitude of bodies ranging from flatbeds to recycling containers and dump bodies.

The Shuttle consists of four basic parts: the base, dump, secondary, and tilt sections. Please take the time to familiarize yourself with the various components. Knowing the proper terminology is necessary to get the full benefit of this manual.

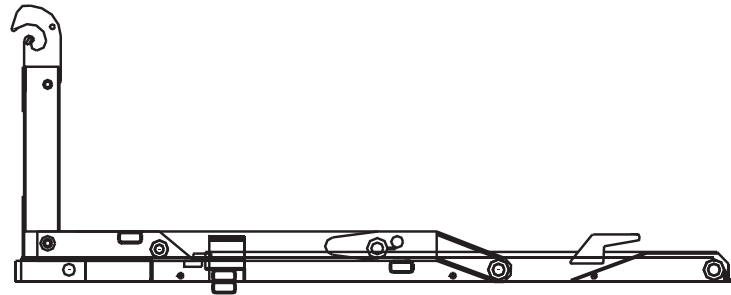

HOOKLIFT

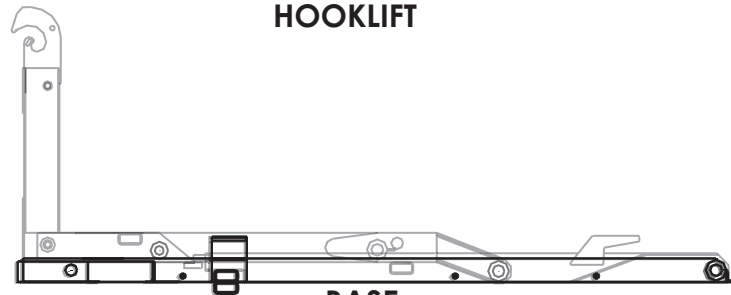

BASE

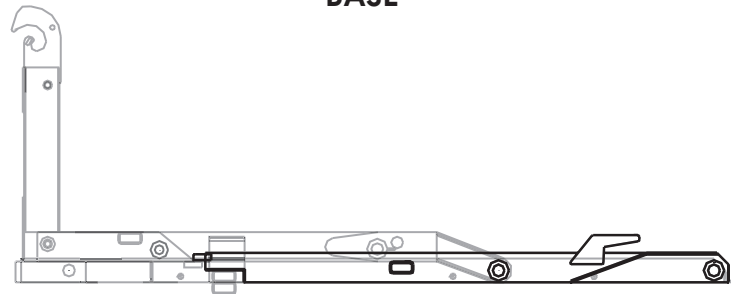

DUMP

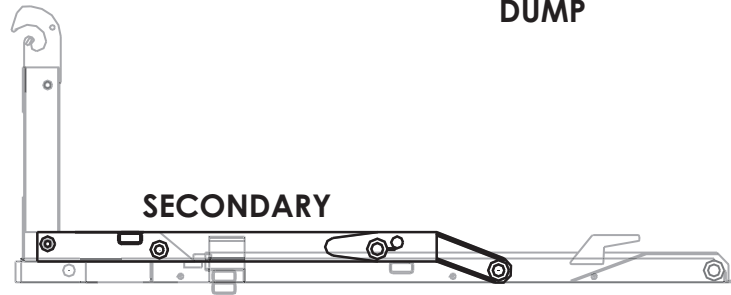

SECONDARY

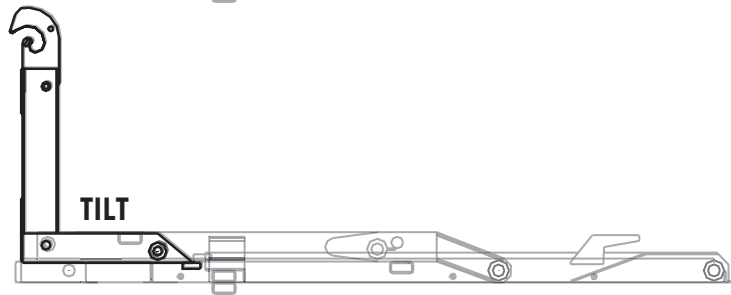

TILT

This page intentionally left blank.

Chapter 1 - Specifications

Model 84-10 Flex Specifications

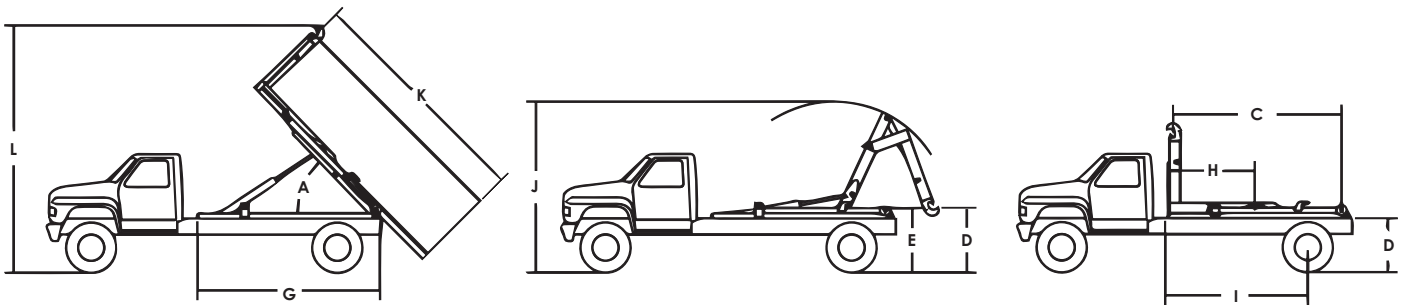

Model 84-10 Flex		
	Lifting/Dumping Capacity	Up to 16,000 lbs (7,257 Kg)
A	Dump Angle	53°
B	Lowest hook Height	25" (635 mm)
C	Effective Length	115" (2,921 mm)
D	Truck Frame Height	36" (914 mm)
E	Hooklift Height	41.5" (1,054 mm)
G	Hooklift Length	126" (3,200 mm)
H	Hooklift Center of Gravity	58" (1,473 mm)
I	Chassis Cab to Axle	84" to 96" (2,134 to 2,438 mm)
J	Max Height When Loading	118" (2,997 mm)
K	Longest Body to Dump	144" (3,658 mm)
L	Max Height when Dumping	162" (4,115 mm)
	Operating Pressure	Variable - See Install Chapter
	Hydraulic Flow	Not to exceed 16 GPM
	Shipping Weight	1,360 (617 Kg)
	Hook Height	35.63" (905 mm)
	Shipping Dimensions (LxHxW)	126" x 49" x 47"

Acceptable Subframe Dimensions - Model 84-10 Flex

SKID W/ 54" HOOK HEIGHT
MUST BE USED WITH TALL
TILT.

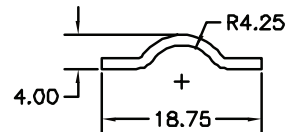
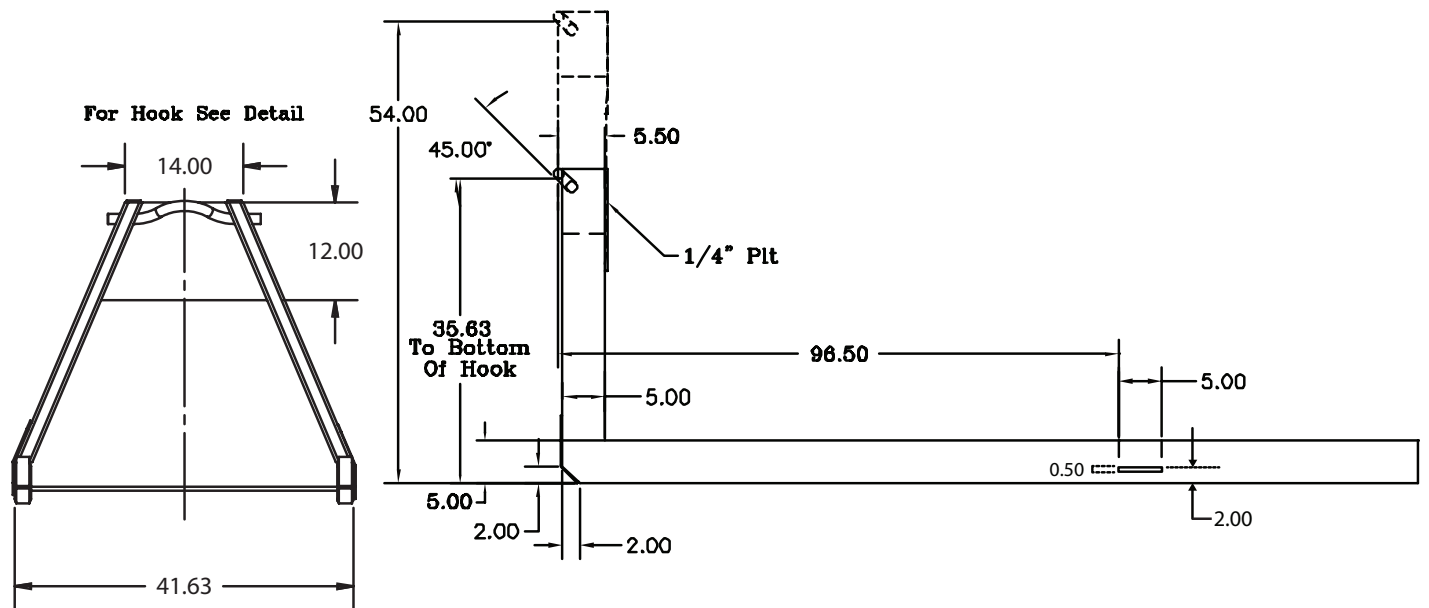

Note: Cap all tube ends.

1.25 Round

Minimum recommended rail construction.	
84-12-8	5x2x1/4
84-12-12	5x2x1/4
84-12-16	5x2x1/4
108-12-20/36	5x2x1/4

Chapter 2 - Installation

General Installation

This chapter is designed to serve as a general guide for the installation of a Stellar® 84-10 Flex Hooklift. Each installation is considered unique so certain portions of this chapter may or may not apply to your direct application. If a question should arise during the installation process, please contact Stellar Customer Service at (800) 321 3741.

PTO and Pump installation instructions are provided by the corresponding manufacturers. For more information on which PTO and Pump fit your application, please contact your local Stellar Distributor or Stellar Customer Service.

⚠ WARNING Do not install this hooklift on a chassis not capable of handling the loads imposed on it. Failure to do so may result in serious injury or death.

Hooklift Mounting and Assembly

Study names and locations of the parts and familiarize yourself with the hooklift before starting the assembly. Reading the step-by-step instructions that follow will be helpful.

Assembly

Select an area for assembly that will be large enough to accommodate the completed unit. The surface of the work area should be as level as possible. Use the proper hand tools to ensure proper bolt tightness. Refer to the torque data chart in this chapter for the recommended torque values for different sizes of bolts.

Model Number

Know the model number of the Stellar® Hooklift being mounted. Use this model number whenever referring to the assembly or parts listing pages. The number is stamped on the name plate which is located on the front frame member.

Installer Notice

According to Federal Law (49 cfr part 571), each final-stage manufacturer shall complete the vehicle in such a manner that it conforms to the standards in effect on the date of manufacture of the incomplete vehicle, the date of final completion, or a date between those two dates. This requirement shall, however, be superseded by any conflicting provisions of a standard that applies by its terms to vehicles manufactured in two or more stages.

Therefore, the installer of Stellar® Hooklifts is considered one of the manufacturers of the vehicle. As such a manufacturer, the installer is responsible for compliance with all applicable federal and state regulations. They are required to certify that the vehicle is in compliance with the Federal Motor Vehicle Safety Standards and other regulations issued under the National Traffic and Motor Vehicle Safety Act.

Please reference the Code of Federal Regulations, title 49 - Transportation, Volume 5 (400-999), for further information, or visit <http://www.gpoaccess.gov/nara/index.html> for the full text of Code of Federal Regulations.

Torque Data Chart

When using the torque data in the chart, the following rules should be observed:

- Bolt manufacturer's particular specifications should be consulted when provided.
- Flat washers of equal strength must be used.
- All torque measurements are given in foot-pounds. To convert to inch-pounds, multiply by 12.
- Torque values specified are for bolts with residual oils or no special lubricants applied. If special lubricants of high stress ability, such as Never-Seez compound graphite and oil, molybdenum disulphite, colloidal copper or white lead are applied, multiply the torque values in the charts by the factor .90. The use of Loctite does not affect the torque values listed above.

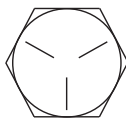
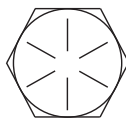
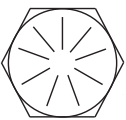
		GRADE 5		GRADE 8		GRADE 9
						
Size (DIA-TPI)	Bolt DIA (Inches)	Plain (Ft-Lb)	Plated (Ft-Lb)	Plain (Ft-Lb)	Plated (Ft-Lb)	Plated (Ft-Lb)
5/16-18	0.3125	17	13	25	18	22
3/8-16	0.3750	31	23	44	33	39
7/16-14	0.4375	49	37	70	52	63
1/2-13	0.5000	75	57	105	80	96
9/16-12	0.5625	110	82	155	115	139
5/8-11	0.6250	150	115	220	160	192
3/4-10	0.7500	265	200	375	280	340
7/8-9	0.8750	395	295	605	455	549
1-8	1.000	590	445	910	680	823
1 1/8-7	1.1250	795	595	1290	965	1167
1 1/4-7	1.2500	1120	840	1815	1360	1646
1 3/8-6	1.3750	1470	1100	2380	1780	2158
1 1/2-6	1.500	1950	1460	3160	2370	2865

- Torque values for socket-head capscrews are the same as for Grade 8 capscrews.
- Do not use these values if a different torque value or tightening procedure is given for a specific application. Torque values listed are for general use only. Check tightness of fasteners periodically.
- Sheer bolts are designed to fail under predetermined loads. Always replace shear bolts with identical grade.
- Fasteners should be replaced with the same or higher grade. If higher grade fasteners are used, these should only be tightened to the strength of the original.
- Tighten plastic insert or crimped steel-type lock nuts to approximately 110 percent of the dry torque values shown in the chart below, applied to the nut, not to the bolt head. Tighten toothed or serrated-type lock nuts to the full torque value. *Note: "Lubricated" means coated with a lubricant such as engine oil, or fasteners with phosphate and oil coatings. "Dry" means plain or zinc plated without lubrication. Tighten lubricated bolts to approximately 80% of dry bolts.*

Installation Note

Every hooklift installation is unique. However, certain guidelines exist that apply to every model. Listed below is a general set of chronological steps that may be followed when installing a Stellar Hooklift. If any questions arise during the installation process, feel free to contact your local dealer or Stellar Customer Service at 800-321-3741.

Step 1: Set the hooklift onto the truck frame.

- Visually inspect the truck and look for any potential issues. For example: Clearance problems, cross members extending too high, insufficient room in front of the hooklift for tarpers, exhaust manifolds, etc., or insufficient room in the rear to allow for bumper selection. *Note: Stellar Industries recommends allowing 12" behind the start of clear truck frame for installation of a tarping system.*
- Be sure to square the hooklift on the truck frame to allow for proper measurement. The front of the hooklift needs to be at least 2.5" behind the cab or any equipment mounted behind the cab.

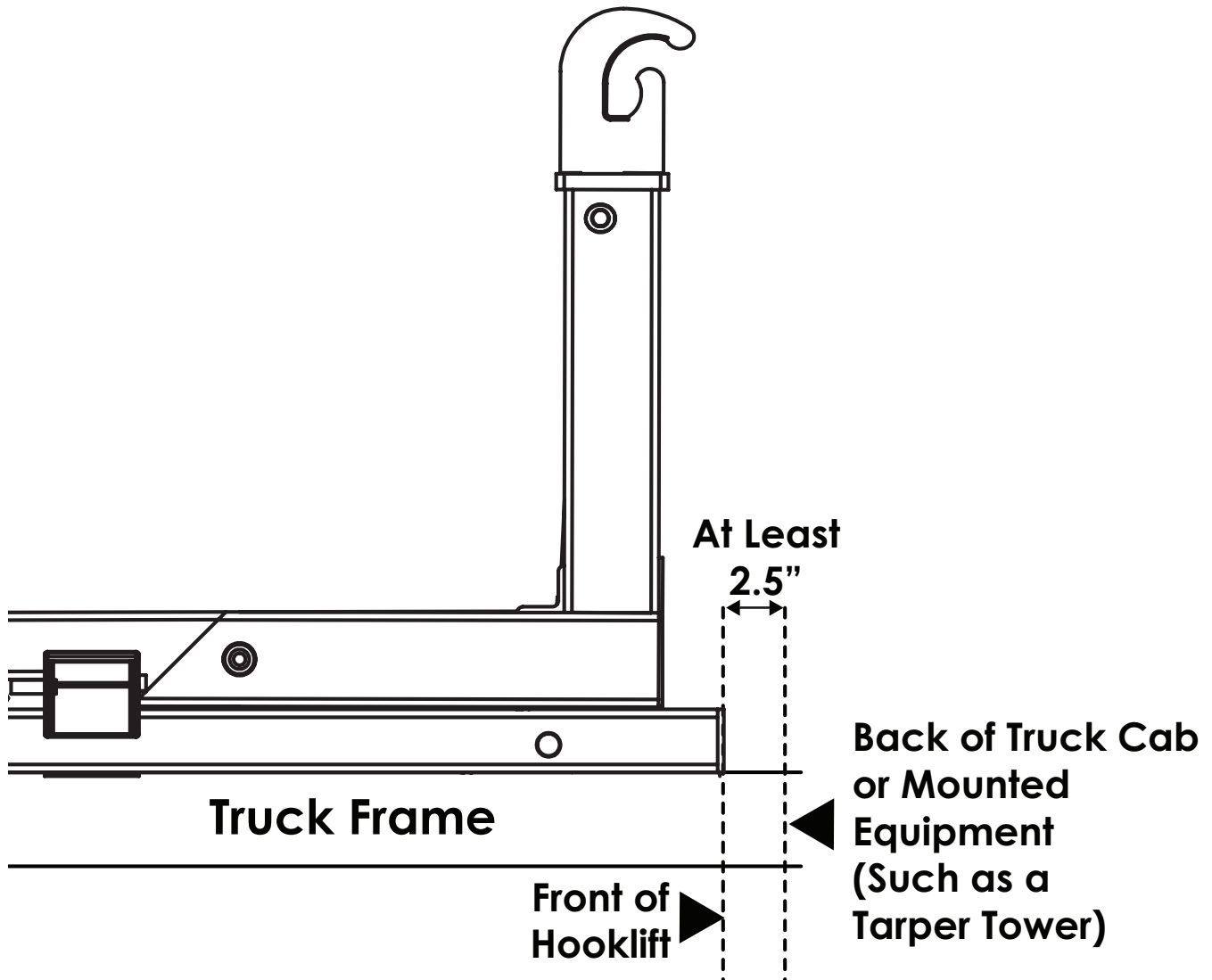

Step 2: Bolt tie-down castings to mounting plates.

Bolt each tie-down casting to the underside of each mounting plate located on the outside of the main rails of the base (both sides):

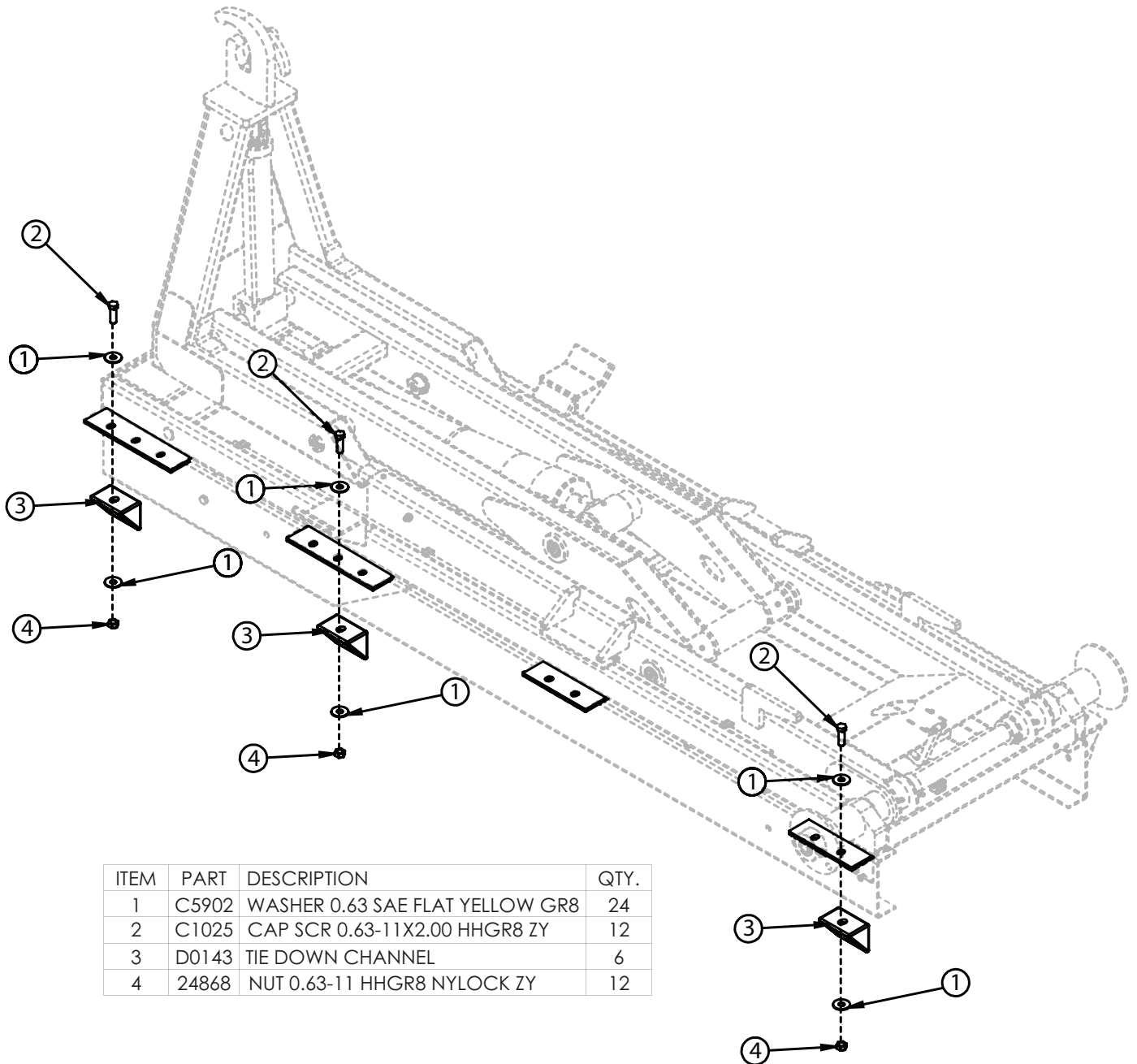

Note: The mounting plates are designed with multiple slots to offer more flexibility in mounting locations. Additional holes may not be added.

Step 3: Drill mounting holes into frame rail.

Using the holes in the tie-down castings as guides, drill $11/16$ " mounting holes through the truck frame as shown (Both Sides):

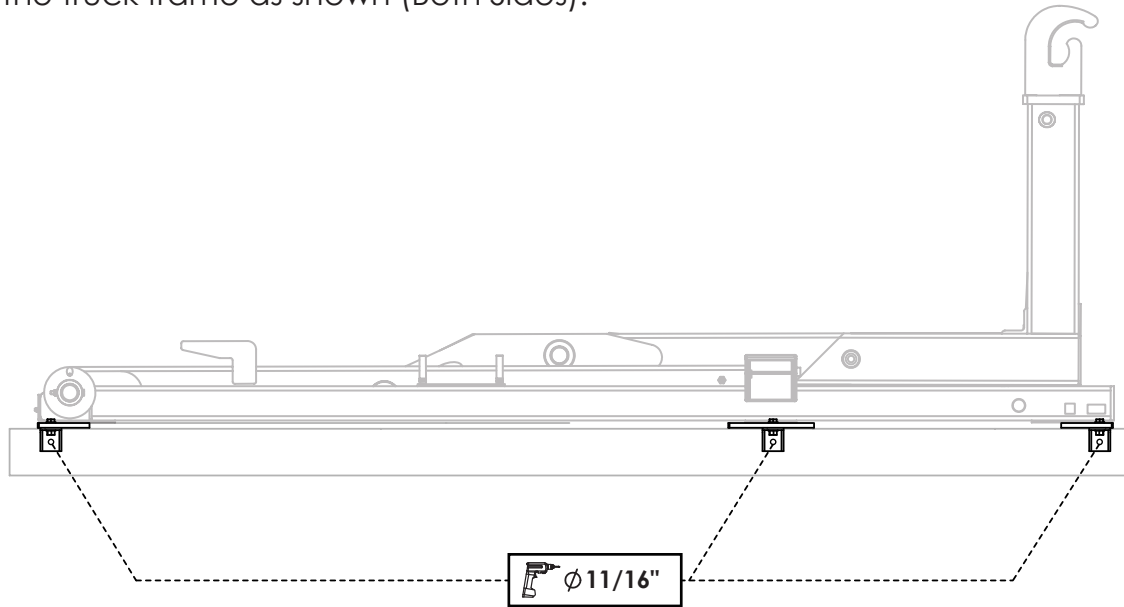

Step 4: Bolt tie-down castings to truck frame.

Bolt each tie-down angle to the truck frame (both sides):

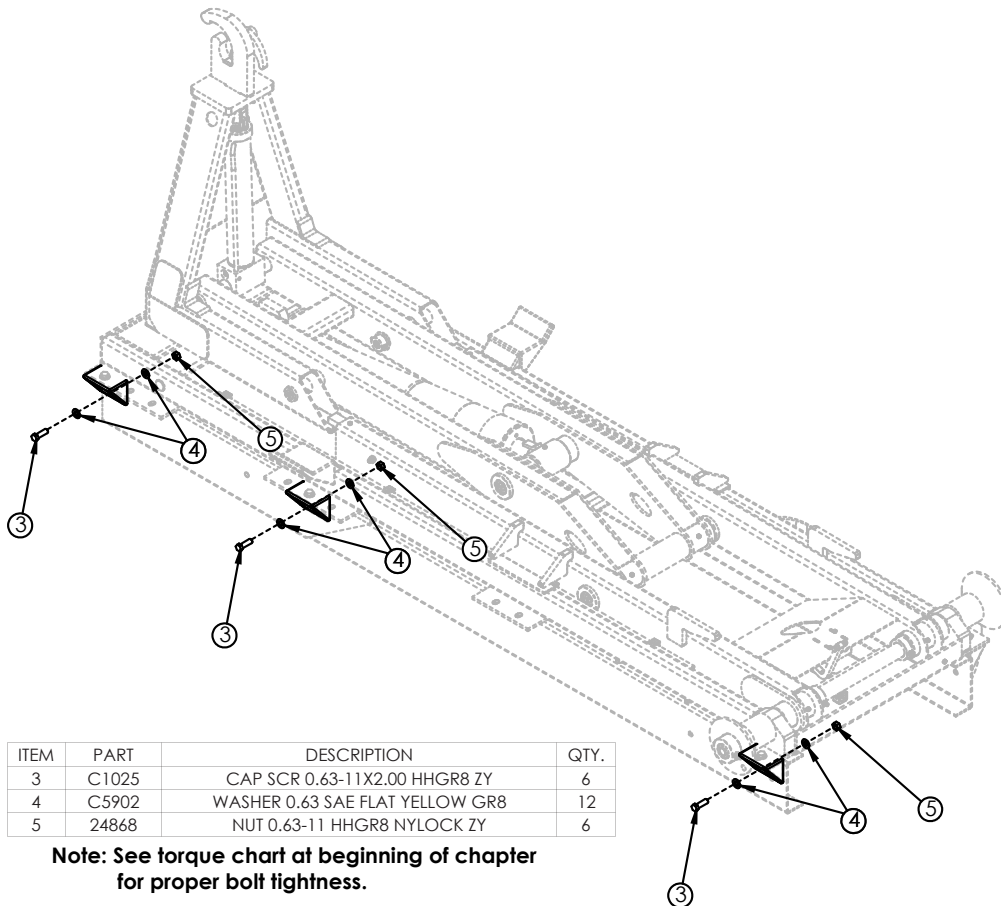

ITEM	PART	DESCRIPTION	QTY.
3	C1025	CAP SCR 0.63-11X2.00 HHGR8 ZY	6
4	C5902	WASHER 0.63 SAE FLAT YELLOW GR8	12
5	24868	NUT 0.63-11 HHGR8 NYLOCK ZY	6

Note: See torque chart at beginning of chapter for proper bolt tightness.

Mounting Kit - PN 23700

PN 23700

ITEM	PART	DESCRIPTION	QTY.
1	D0143	TIE DOWN CHANNEL	6
2	C1026	CAP SCR 0.63-11X2.50 HHGR8	12
3	C5902	WASHER 0.63 SAE FLAT YELLOW GR8	24
4	24868	NUT 0.63-11 HHGR8 NYLOCK ZY	12

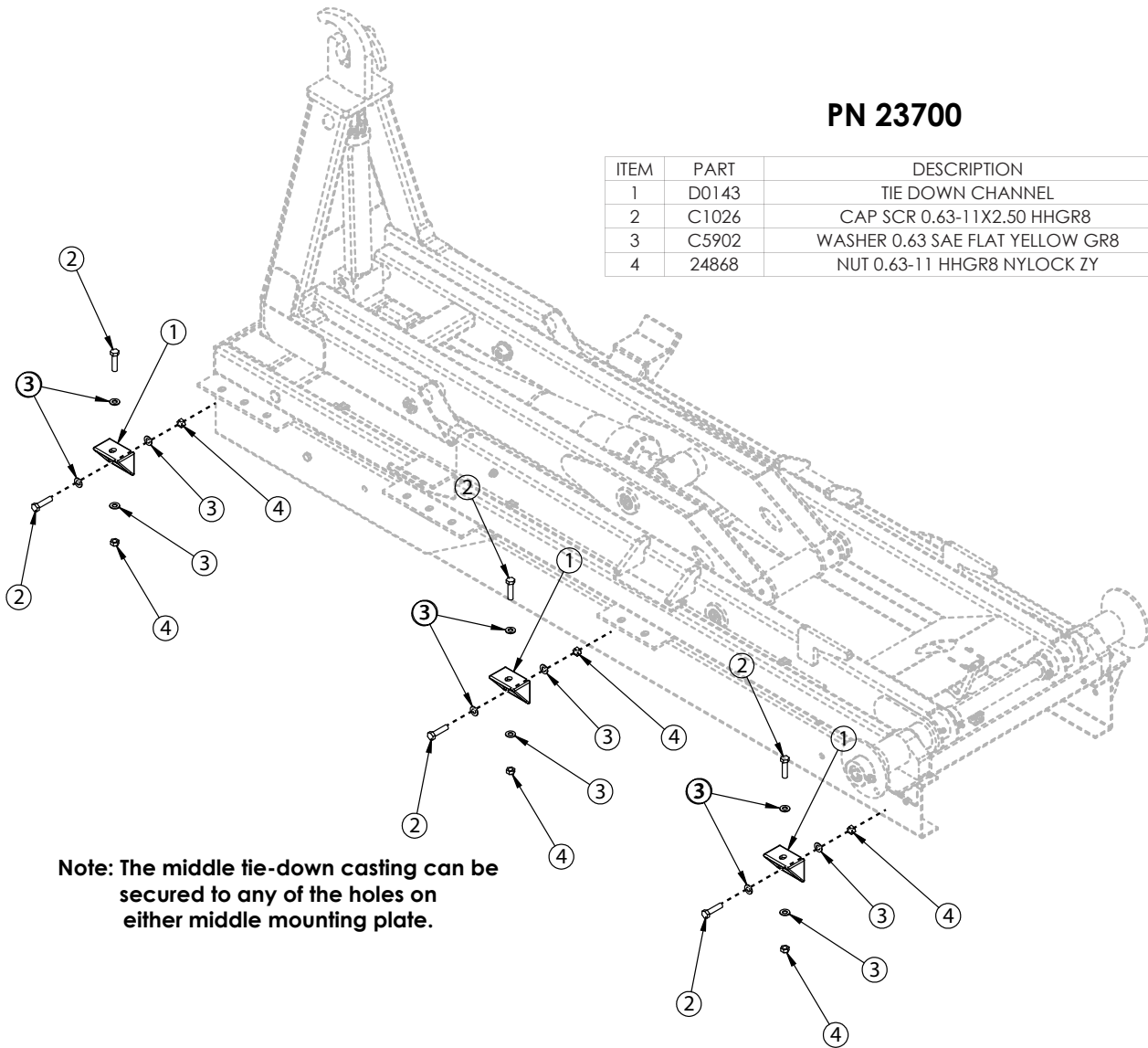

Step 5: Install bumper.

- See NHTSA (National Highway Truck Safety Administration) Regulations for acceptable placement.
- Modify the truck frame as necessary so that it ends 2" from the rear of the hooklift.

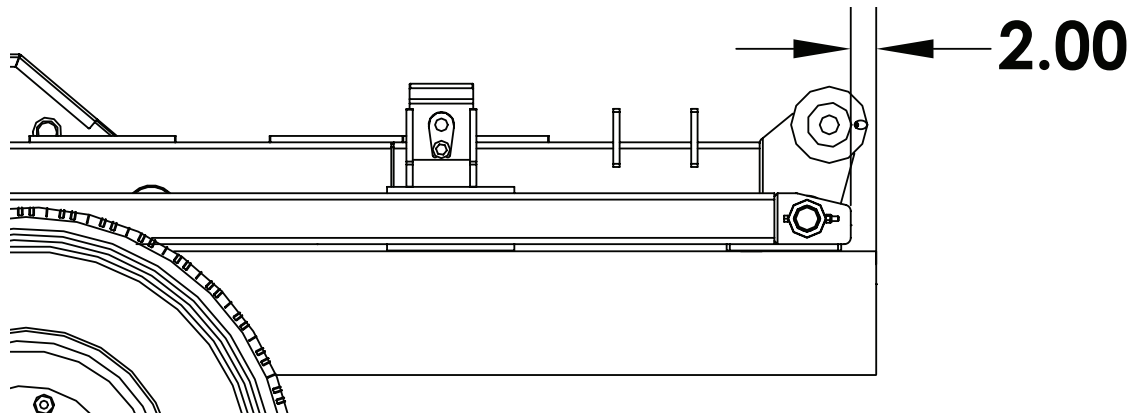

Step 6: Install taper tower (If applicable).

See brand specific installation instructions.

Step 7: Install hydraulic reservoir and valve bank.

- Before drilling and bolting to the frame, confirm adequate room for cable routing between in-cab controls and the valve bank. **Note: The top of the reservoir should not be above the truck frame.**

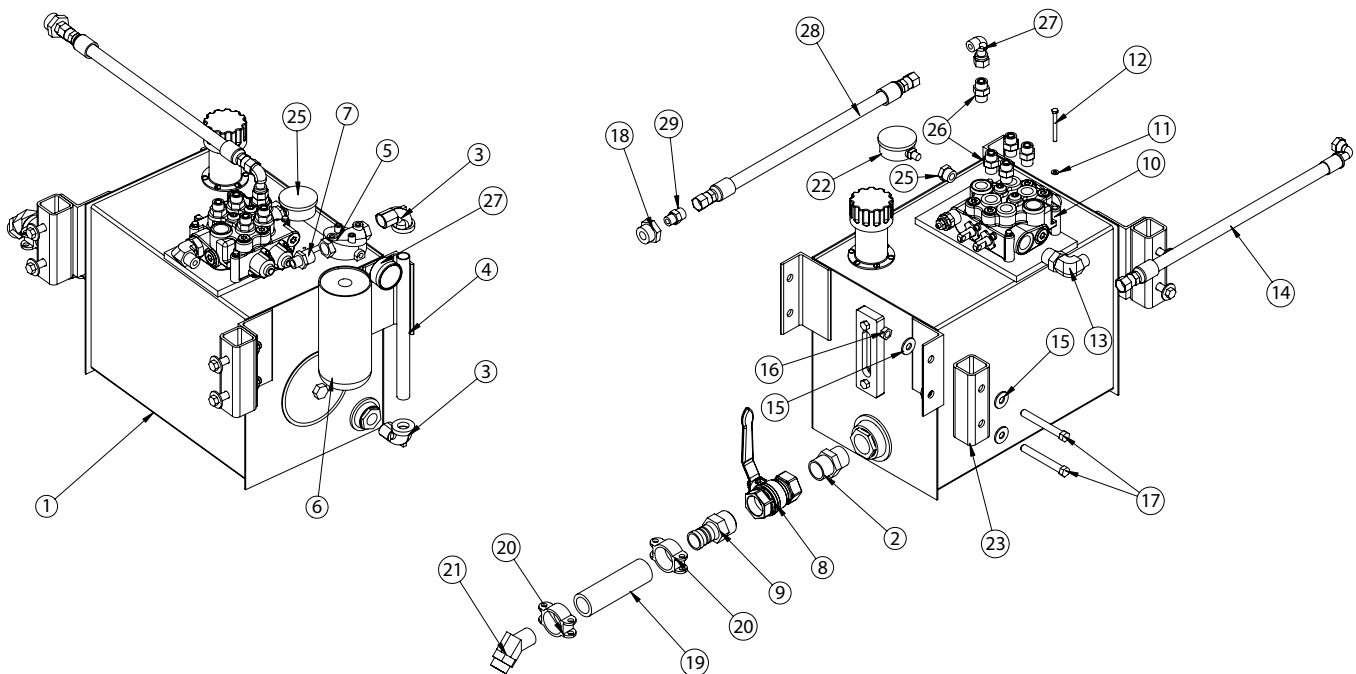

PN 35883

ITEM	PART	DESCRIPTION	QTY.	ITEM	PART	DESCRIPTION	QTY.	ITEM	PART	DESCRIPTION	QTY.
1	26455	RSRVR ASM 10GAL K MODEL	1	13	C4227	FTG MF/MSTR 90 8-12 C5OLO-S	1	25	25630	FTG ADAPT 10-1/4 F5OG	1
2	1115	FTG NIPPLE HEX MALE 0101-20-20	1	14	26731	HOSE 0.50(381-JC-J9-8-8-8-18-0)	1	26	C2252	FTG ADAPT 8-10-F5OLO-S	5
3	c2242	ST EL 0.75 90 DEG BLK	2	15	0352	WASHER 0.50 USS FLAT ZINC	8	27	C2376	FTG ADAPT 8-C6LO-S	1
4	3320	NIPPLE 0.75X12.00 PIPE	1	16	C6106	NUT 0.50-13 HHGR5 NYLOC	4	28	31676	HOSE 0.50(471TC-JC-JC-8-8-8-120)	1
5	c6226	FILTER HEAD	1	17	0506	CAP SCR 0.50-13X4.00 HHGR5	4	29	1554	FTG ADAPT 8-F5OLO-S	1
6	C6229	FILTER LARGE AE-10L	1	18	D0549	FTG ADAPT 16-8 F5OG5-S	1				
7	C6014	FTG ADAPT 8-12 FOLO-S	1	19	17767	HOSE SUCT 1.25 10FT	1				
8	C5511	VALVE BALL 1.25	1	20	C1123	HOSE CLAMP 88 DB-20	2				
9	C2282	FTG 1.25 NPT TO 1.25 BARB	1	21	C4747	NIPPLE O'RING 45 4603-20-16	1				
10	24611	VB 2-SECTION VDM8	1	22	10094	GAUGE OIL LF 2.5" 0-500 BM	1				
11	0521	WASHER 0.25 LOCK	3	23	9892	SPACER TANK MOUNTING 10 GAL	2				
12	0339	CAP SCR 0.25-20X2.50 HHGR5	3	24	16145	GAUGE PRES FILTER SERVICE C120	1				

Step 8: Install PTO and pump.

- Before installing the pump to the PTO, always check the direction of the PTO output shaft to determine which direction the hydraulic pump needs to rotate to operate the equipment. If this is not determined prior to installing the hydraulic pump, the hydraulic pump may rotate in the incorrect direction and damage the front shaft seal.

PTO Direction of Rotation Tip:

Viewed by standing at the rear of the vehicle, looking forward at the PTO shaft, with the PTO shaft pointing toward the rear of the vehicle:

P.T.O.	Driven Equipment
Rotates Opposite Engine (looks "clockwise")	Driven equipment must rotate counterclockwise (also called left-hand rotation, "A" for anti-clockwise or C.C.W. for counter clockwise).
Rotates With Engine (looks "counterclockwise")	Driven equipment must rotate clockwise (also called right-hand rotation or "C" for clockwise).

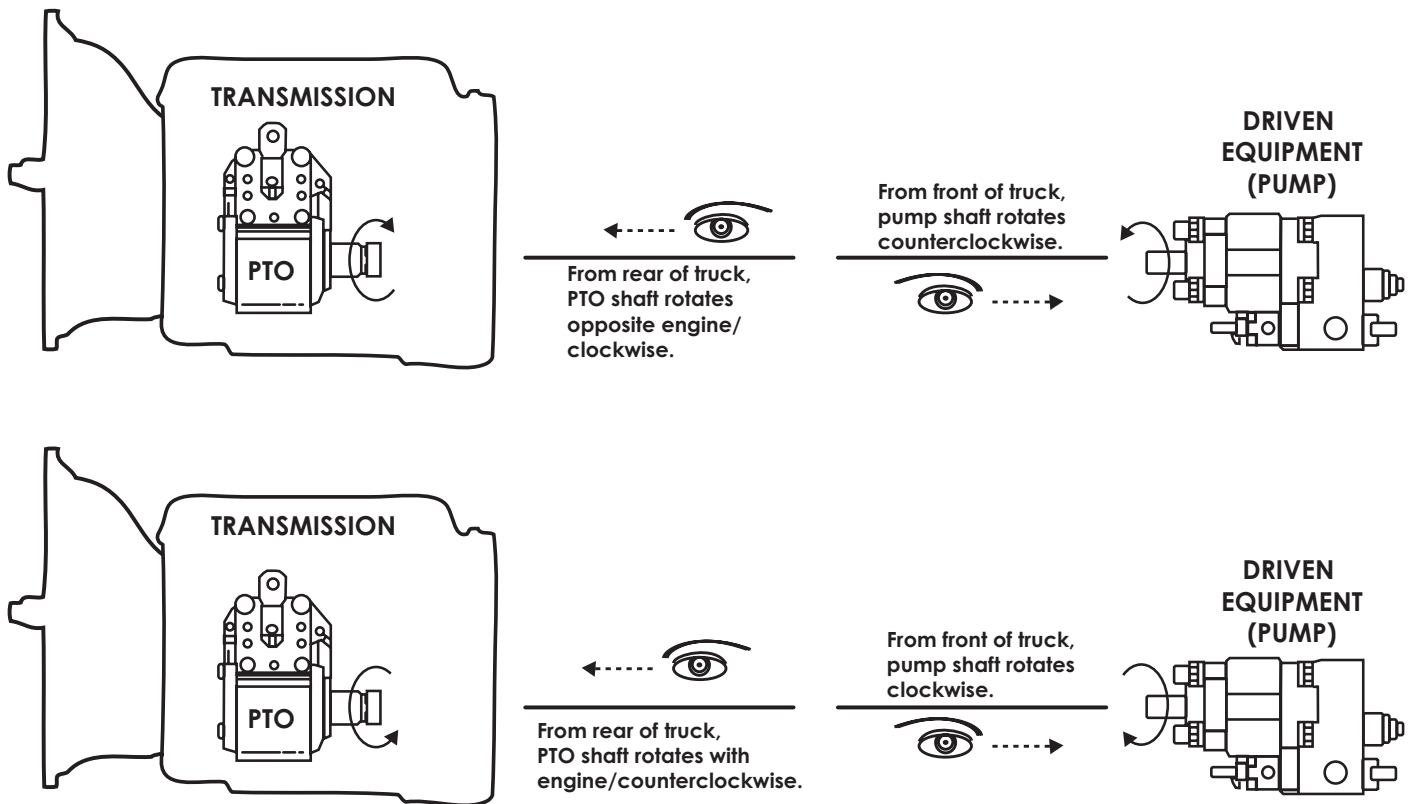

Remember that the PTO is specified by looking from the rear of the truck to the front of the truck. The driven equipment (pump) is specified by looking from the front of the truck to the rear of the truck.

- Use the brand specific PTO/Pump installation instructions. If the directions are not quite clear, contact Stellar® Customer Service or consult with a hydraulic specialty house or company prior to installation.

Face Seal/O-Ring Size Chart

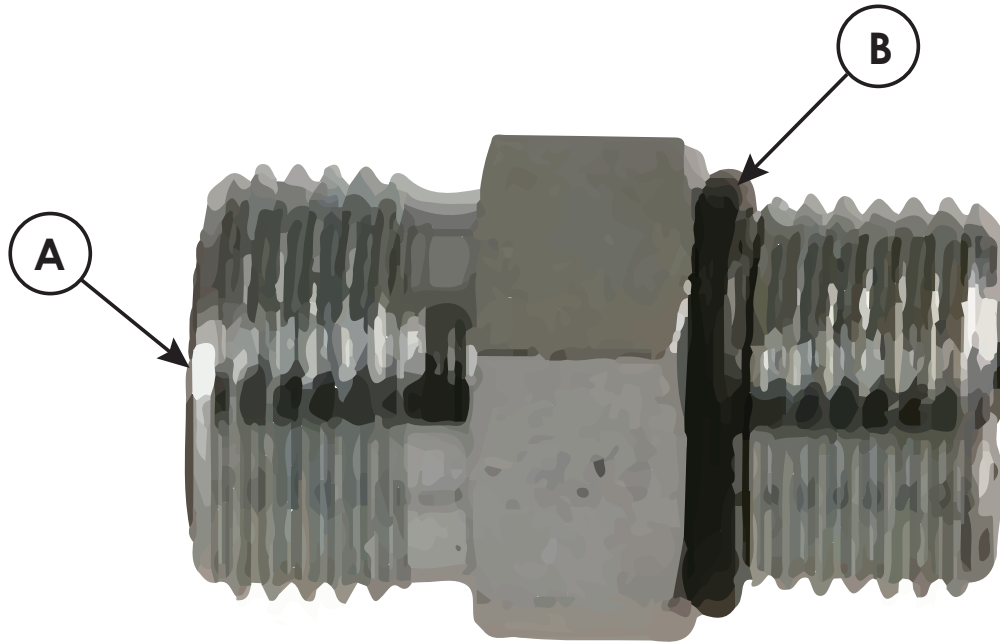

Hose Size	Fitting Size	Face Seal (A) Stellar® PN	O-ring Boss (B) Stellar® PN
1/4"	#4	C2027	D1245
3/8"	#6	C2028	D1246
1/2"	#8	C2029	D1247
5/8"	#10	32223	D1248
3/4"	#12	D1244	D1249
1"	#16		D1250

Step 9: Route hydraulic hoses.

1. Route hose line from the reservoir to the pump (See hose kit drawing for details).
2. Route hose line from the pump to the valve bank (See hose kit drawing for details).
3. Route hose line from the valve bank to the reservoir (See hose kit drawing for details).
4. Route hose line from the valve bank and the hooklift (See hose kit drawing for details).

Note: If using the Power Beyond feature for additional function, see "Power Beyond VDM8 Valve" later in this chapter for further details.

Notes on hose line routing:

- Protect these lines with hose wrap when necessary.
- Keep these lines away from sharp edges.
- Keep these lines away from the exhaust or other temperature extreme items.
- Keep these lines away from the driveshaft or other moving items.

Hose Kit - PN 72354

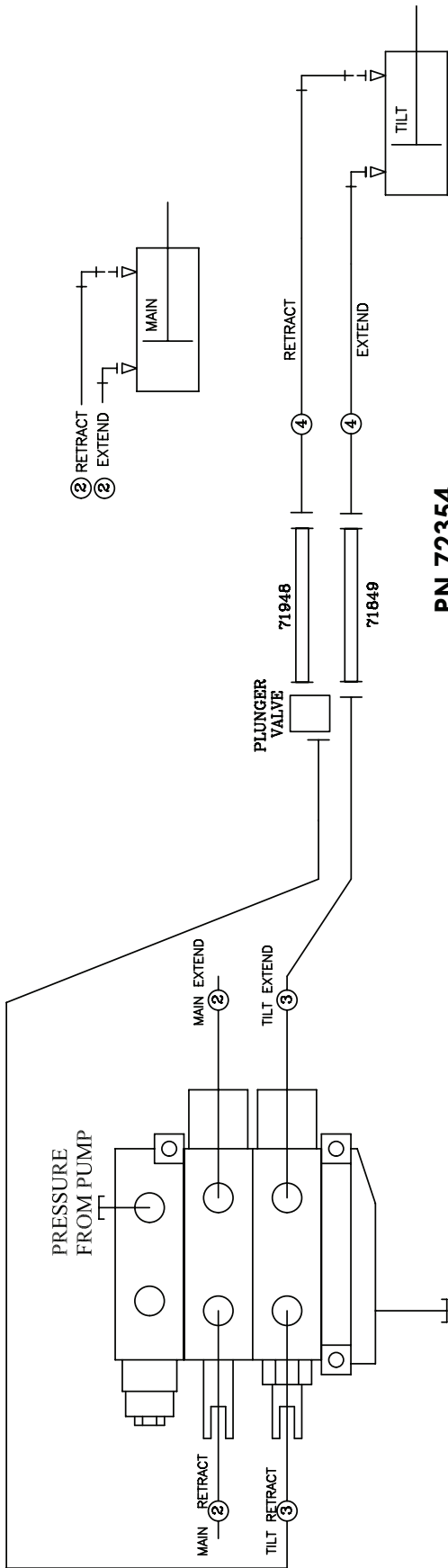

PN 72354

ITEM	PART No.	DESCRIPTION	QTY
04	72349	HOSE 0.38(4500PSI)-8MFS-6FFSS 90 SHORT-156CL	2ref
03	34644	HOSE 0.38(4500PSI)-8MFS-8FFSS 90 SHORT-60CL	2ref
02	18169	HOSE 0.50(4500PSI)-8FFSS SHORT-8FFSS 90 SHORT-60CL	2ref
01	34647	HOSE KIT 84-10 FLEX 36 W/PLUNGER VALVE	1

ITEM	PART No.	DESCRIPTION	QTY
②	STELLAR #18169-0.50(4500PSI)-8FFSS SHORT-8FFSS 90 SHORT-60CL	<p>FUNCTION: MAIN CYLINDER</p>	QTY - 2
③	STELLAR #34644-0.38(4500PSI)-8MFS-8FFSS 90 SHORT-60CL	<p>FUNCTION: TILT VB TO PORT TUBES</p>	QTY - 2
④	STELLAR #72349-0.38(4500PSI)-8MFS-6FFSS 90 SHORT-156CL	<p>FUNCTION: PORT TUBES TO TILT CYLINDER</p>	QTY - 2

NOTE: SYSTEM PRESSURE IS 4500 P.S.I.

Power Beyond VDM8 Valve

These instructions are intended for correct installation of power beyond on a Salami VDM8 valve bank. If any hydraulic component is integrated after this valve the power beyond must be installed correctly, or serious damage may incur to the hydraulic system.

1. Remove cover/access plug to reveal the power beyond access point. Can also be used as the Return/Tank port.
2. Install 3/8" straight thread pipe plug (PN 5597) into lower portion of cavity to activate the power beyond feature. Use thread sealer (tape sealers not recommended).

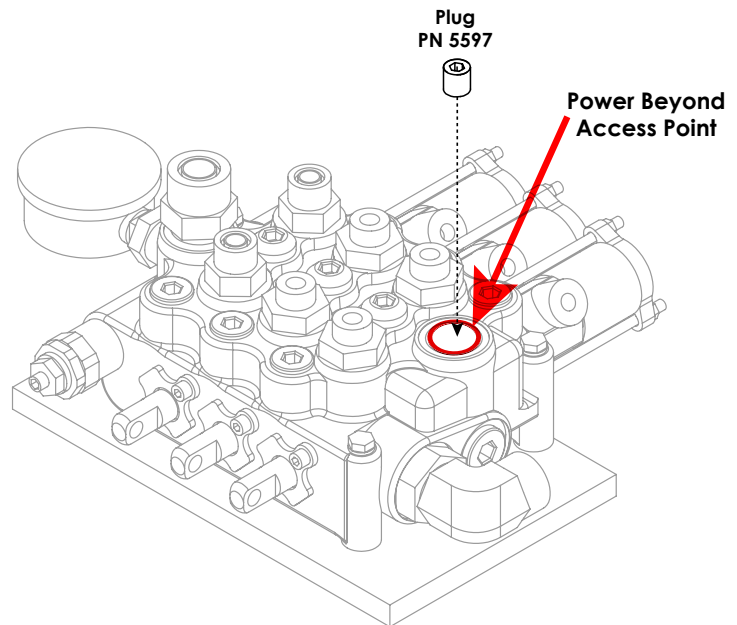

3. The Power Beyond feature is now activated and will divert oil to alternate system via the port shown.

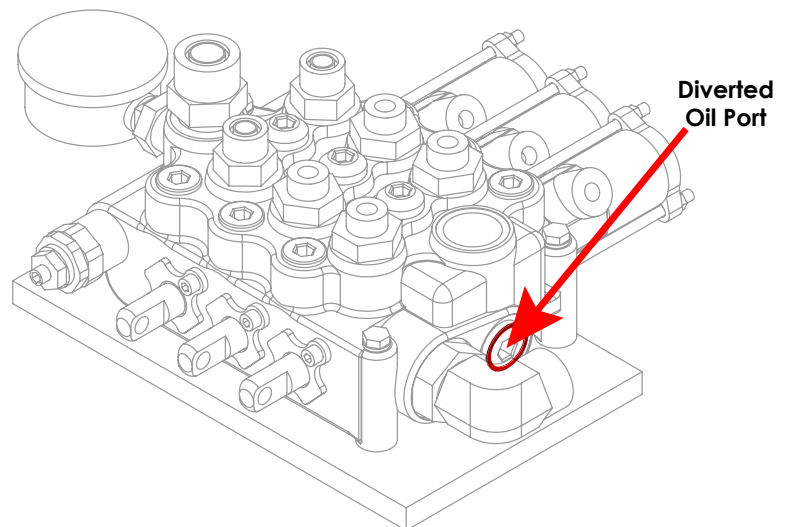

Notes:

- The return/tank line must be connected to the top or the side port, labeled "T".
- Using the return line to run auxiliary equipment will directly result in a failure and will not in any circumstance be covered under warranty.
- A standard Stellar® Hooklift will have 6 hydraulic lines attached to the valve. With Power Beyond activated, they will have 7 hydraulic lines attached to the valve.

Optional - Port Side Relief Installation

- For some options, port side relief is required.
- To install port side relief:
 1. Remove plug.
 2. Insert relief.
 3. Replace plug
- Relief can be installed on the retract or extend side of the valve bank.

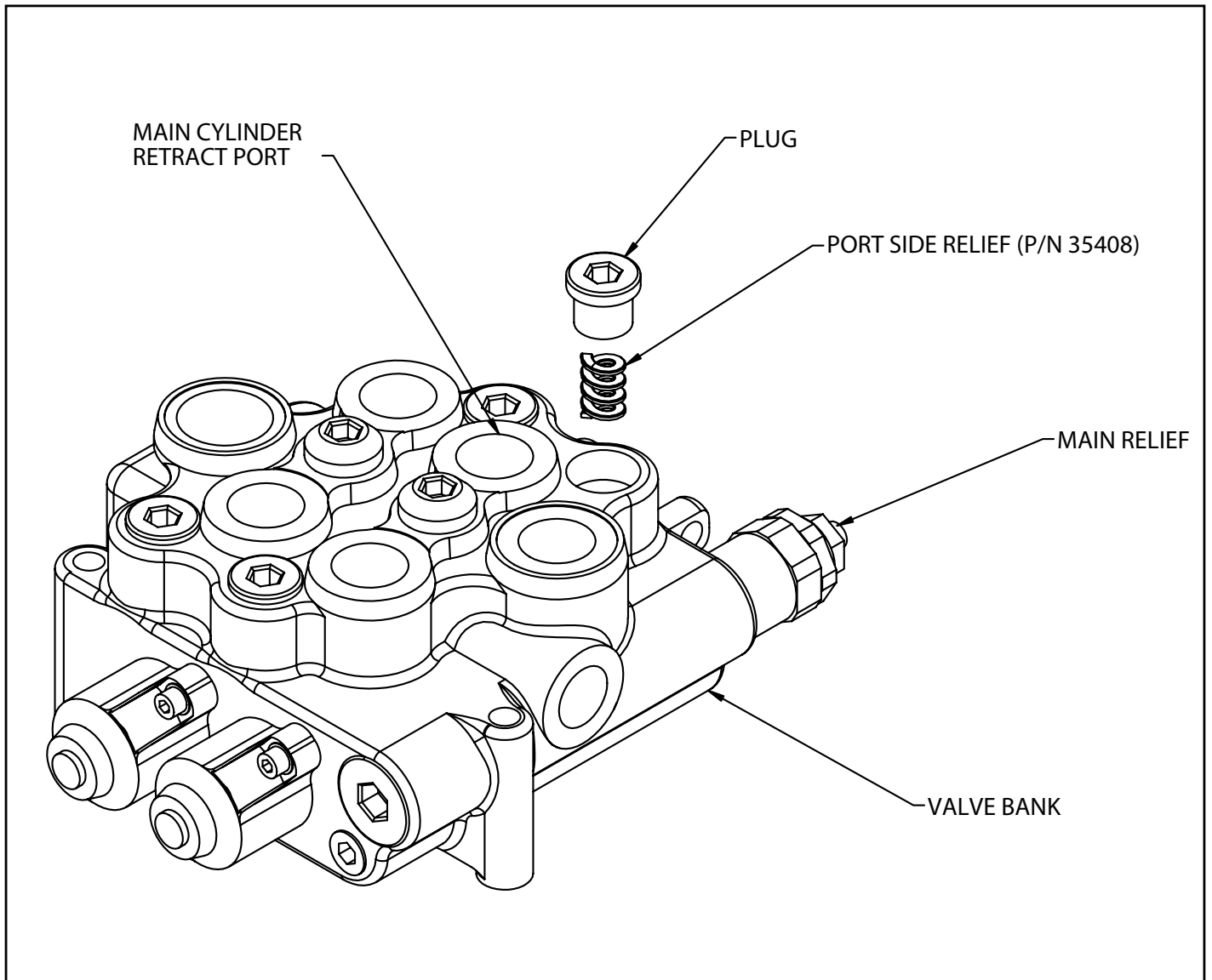

Step 10: Route Electrical Components

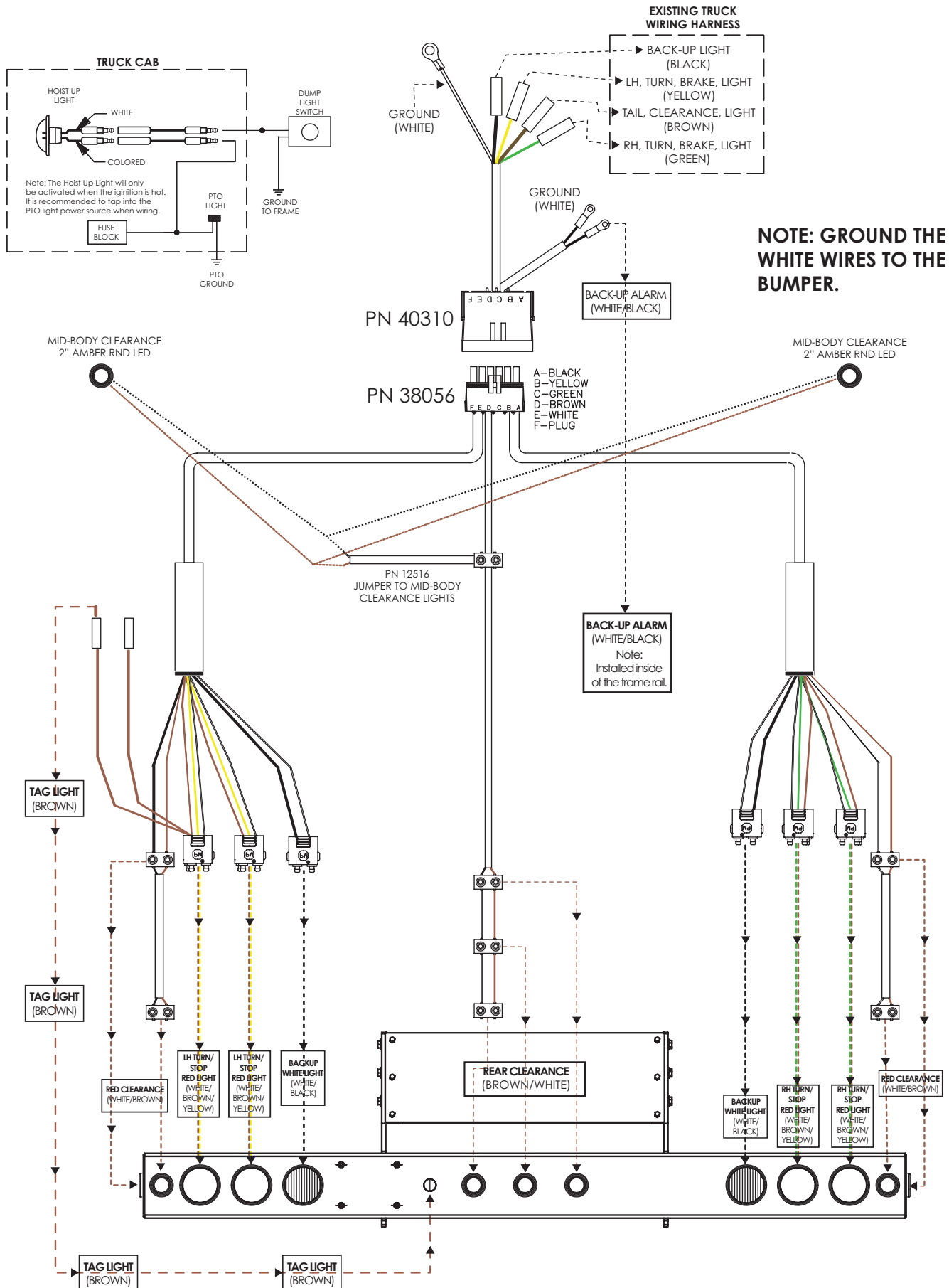

Step 11: Install cab and PTO controls.

- Use PTO brand specific installation instructions.
- For cab controls, see controller assembly drawing for details:

	2 SECTION	3 SECTION
96 INCH	PN 50835	PN 50836
144 INCH	PN 53444	PN 53445
192 INCH	PN 50837	PN 50838

In Cab Installation

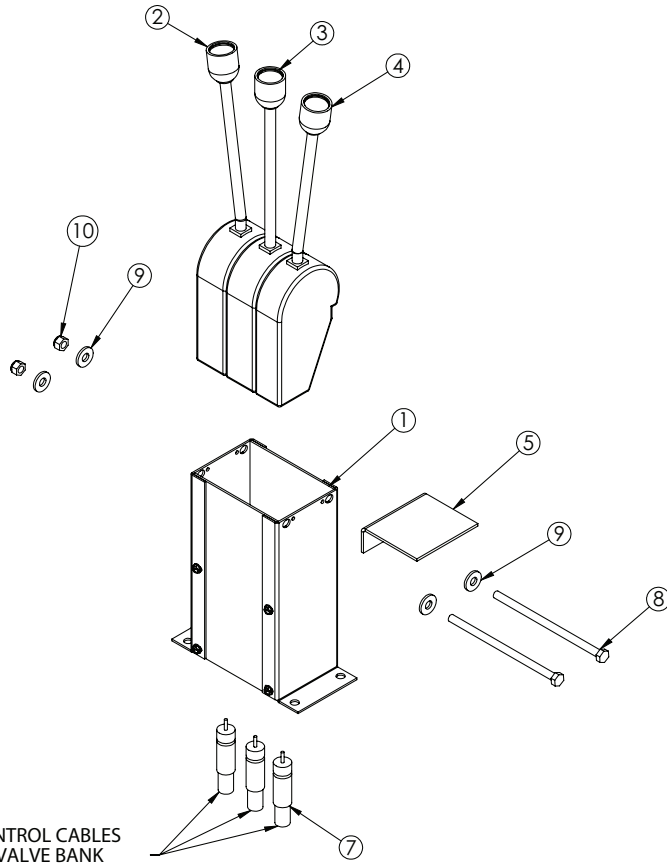

CONTROL CABLES
TO VALVE BANK

At Valve Installation

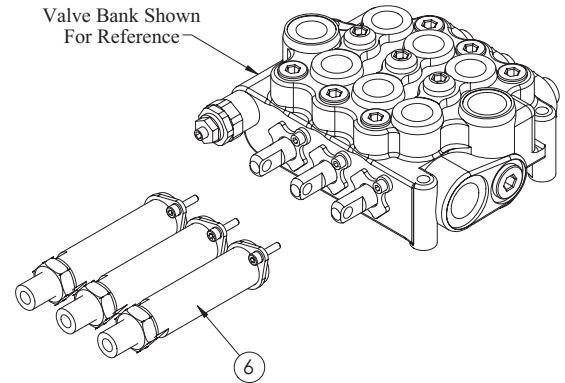

ITEM	PART	DESCRIPTION	QTY.
1	38351	VALVE CTRL CONSOLE 3LEVER RVC (3-Section)	1
1	37470	VALVE CTRL CONSOLE 2LEVER RVC (2-Section)	1
2	37475	CTRL CNTR LOCK LEFT BEND	1
3	37476	CTRL CNTR LOCK NO BEND	1
4	37474	CTRL CNTR LOCK RIGHT BEND	1
5	25933	BRKT CONTROLLER DECAL	1
6	37469	CABLE CONN. KIT FOR VD8A/VDM8	3
7	37471	CONTROL CABLE 96 IN WESCON	2/3
7	37472	CONTROL CABLE 144 IN WESCON	2/3
7	37473	CONTROL CABLE 192 IN WESCON	2/3
8	20057	CAP SCR 0.31-18X6.50 HHGR5 (3-Section)	2
8	20057	CAP SCR 0.31-18X4.00 HHGR5 (2-Section)	2
9	0343	WASHER 0.31 USS FLAT ZINC	4
10	0342	NUT 0.31-18 HHGR5 NYLOC	2

Step 12: Install mud flaps and fenders.

See brand specific installation instructions.

Step 13: Install Hoist Up Light Sensor - PN 31806

Install the hoist up light sensor onto the base of the hooklift as shown:

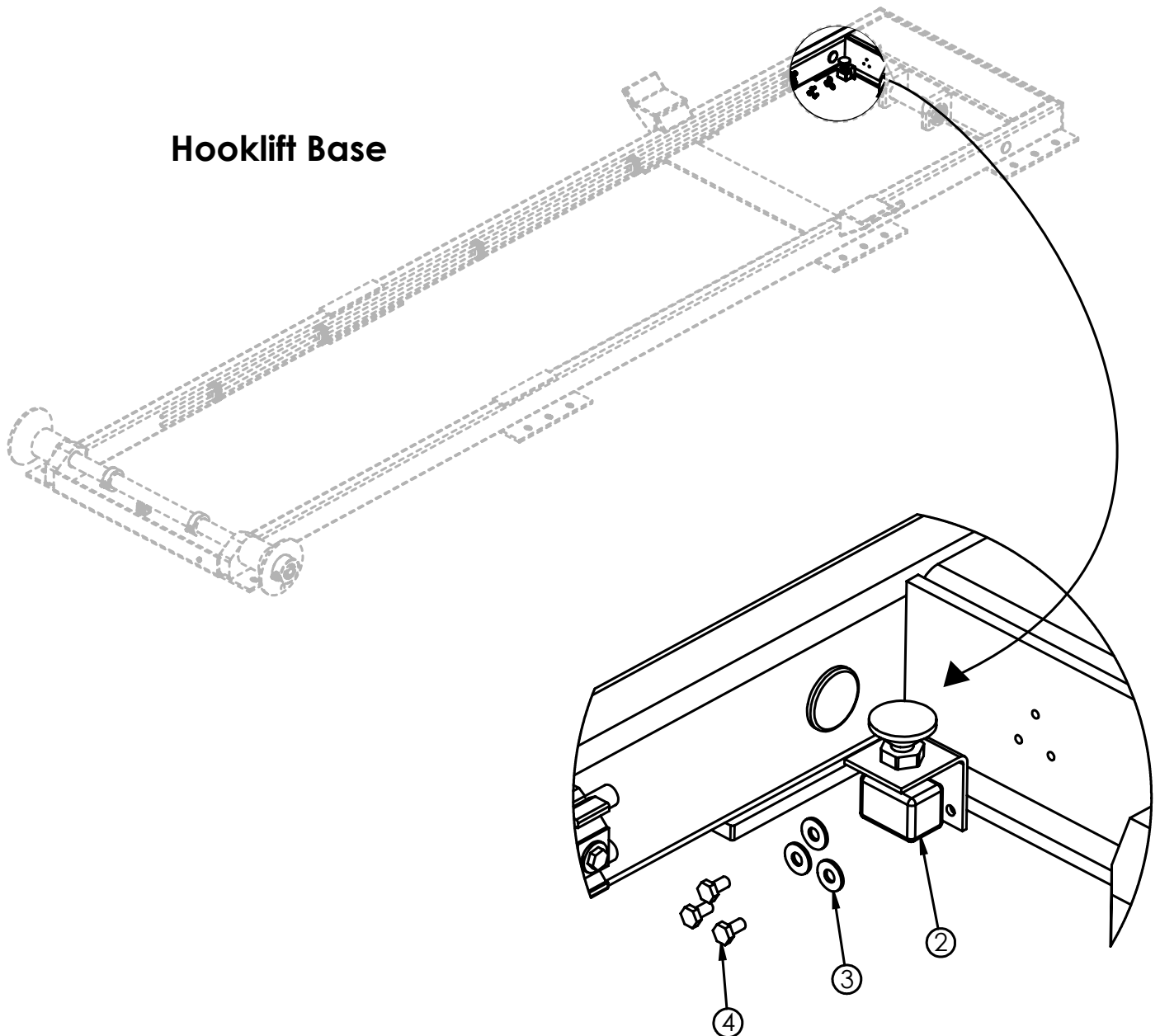

PN 31806

ITEM	PART	DESCRIPTION	QTY.
2	31806	DUMP UP LIGHT KIT BUYERS SK10	1
3	0340	WASHER 0.25 FLAT	3
4	0478	CAP SCR 0.25-20X0.50 HHGR5	3

Step 14: Apply Decals

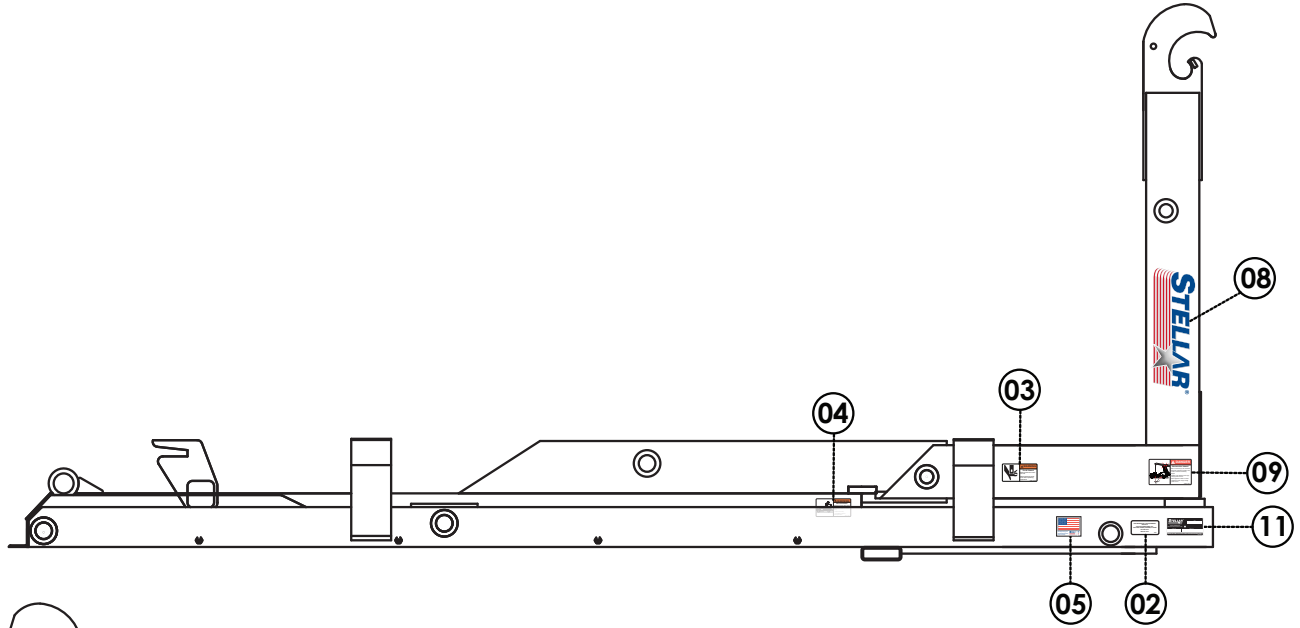

Last Revision

Rev Level: F
 Date: 05/14/15
 Changes: Added: 35234

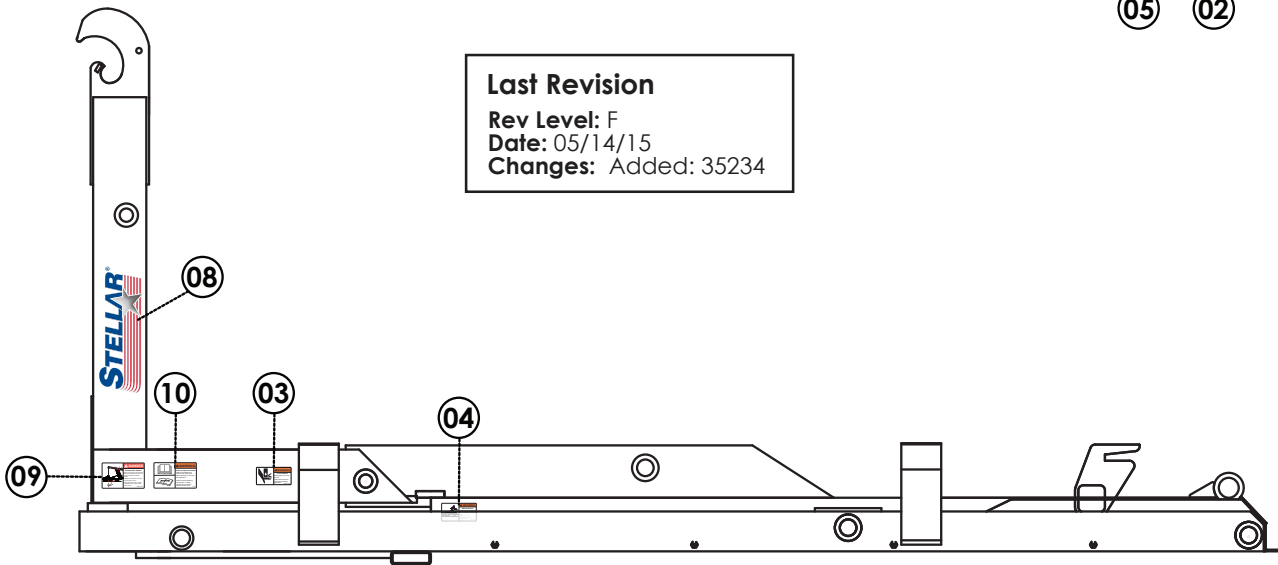

PN 35559

ITEM	PART NUM	DESCRIPTION	QTY
01	0651	DECAL SHUTTLE CONTROLS	1
02	4214	DECAL CONTACT STELLAR	1
03	25627	DECAL WARNING CRUSH	2
04	26134	DECAL WARNING MISUSE TABS	2
05	35234	DECAL STELLAR MADE IN THE USA	1
06	39211	DECAL HOOKLIFT LEVER LIFT	2
07	39212	DECAL HOOKLIFT LEVER TILT	2
08*	53850	DECAL STELLAR LOGO 4.00X11.50	3
09	55832	DECAL DANGER ELECTROCUTION HOOK	2
10	68024	DECAL WARNING UNTRAINED OPERATOR	1
11**	C5942	PLATE STELLAR SERIAL	1

CONTROL ASSEMBLY

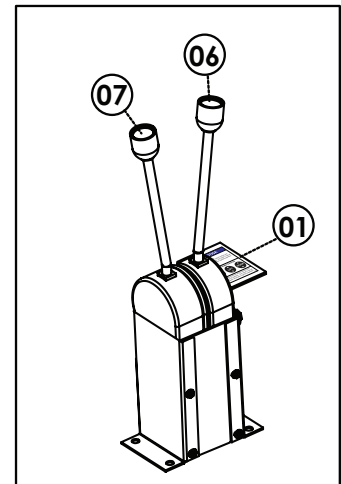

*Extra QTY 1 shipped loose.

**This item not included in decal kit.

Step 15: Fill reservoir and activate hydraulic flow.

- Fill reservoir to site gauge, within 3" from the top (Roughly 10 Gallons). Note: ISO 32 hydraulic oil is recommended.
- When connections are secure, activate hydraulic flow by opening the ball valve on the bottom of the reservoir. This will allow oil to flow from the reservoir to the pump.

Step 16: Operate hooklift.

- **⚠ WARNING** Stellar® Hooklift operators must conform to the qualifications specified in the *Slider Hooklift Safety, Operation, Maintenance, Troubleshooting Manual*. Read and understand all manuals and safety signs before operating or servicing this equipment.
- Bleed the air out of the hydraulic system.
- Check the hydraulic oil level and add oil if needed. When checking hydraulic oil level, make certain that **all system cylinders** are fully retracted.
- Calibrate dump light system.
- Be sure to check all clearances.
- Set/check relief pressure no higher than 4200 PSI (See procedure on next page).

Pressure vs. Capacity

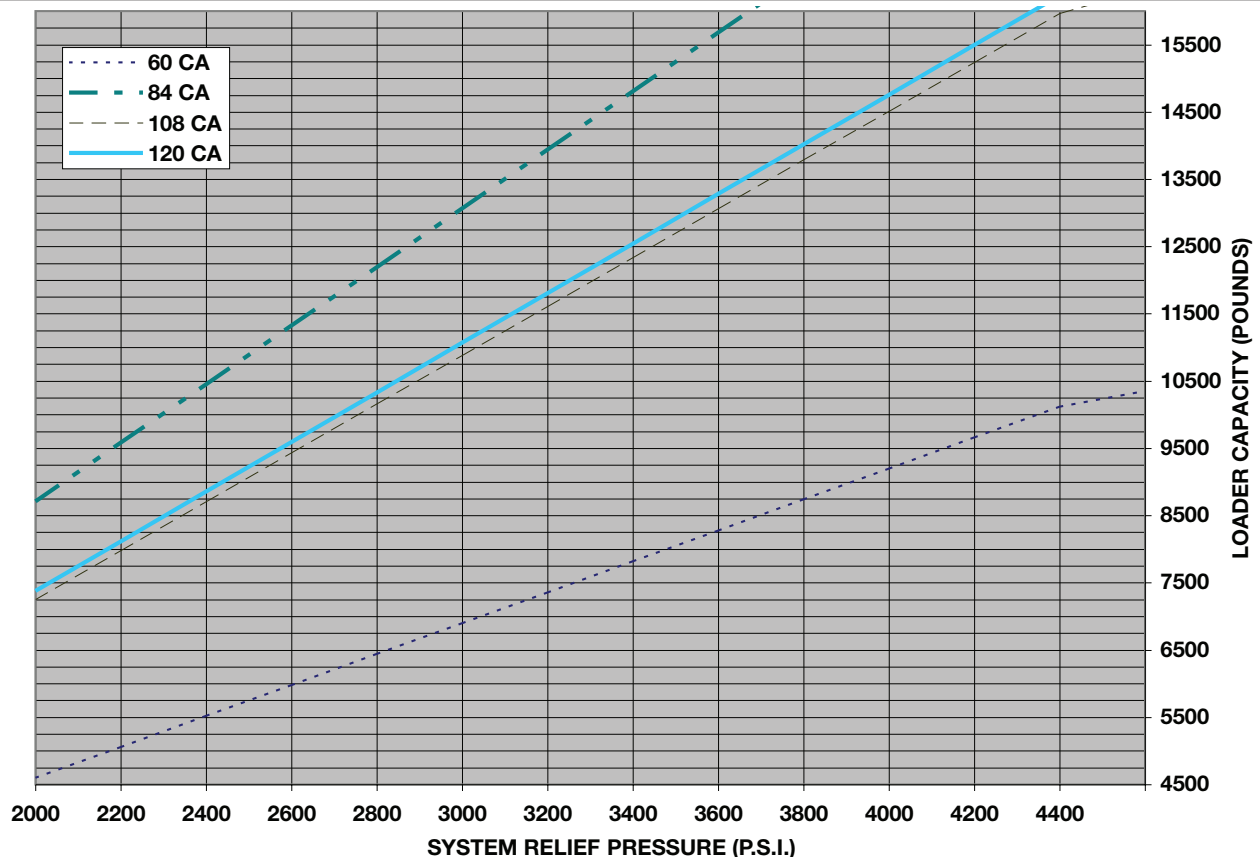

Set System Relief Pressure

1. Engage the PTO. Run the PTO at 1200 RPM.

2. Push the lever labeled 'lift' until the boom bottoms out. Keep pushing the lever forward until the pressure is set.

3. Locate the main relief valve and release the jam nut using a 13 mm wrench:

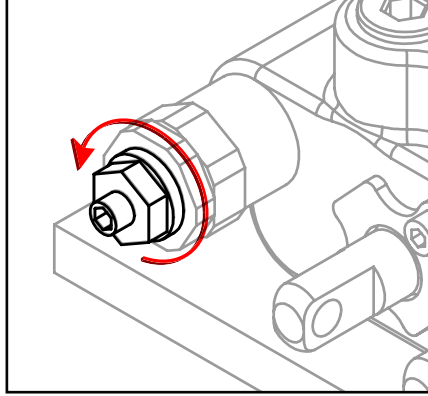

4. Adjust the system relief pressure using 4 mm allen wrench (See chart on previous page). Clockwise increases pressure, counter clockwise decreases pressure:

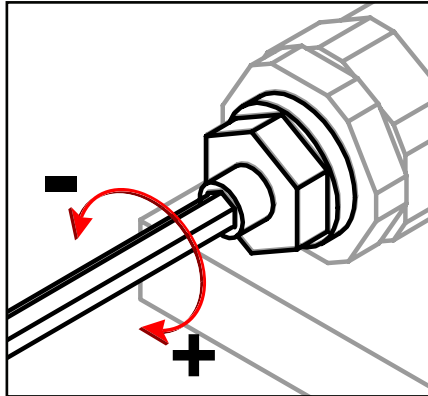

5. Once system pressure is set, tighten the jam nut to lock system pressure. Permanent thread lock should not be used:

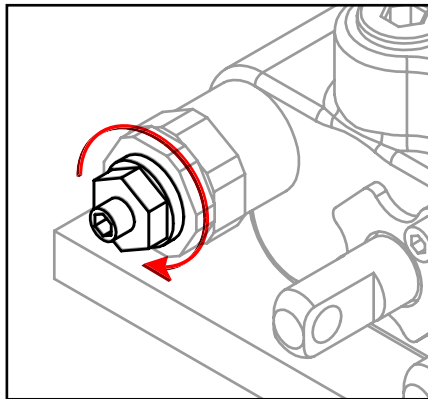

6. Release all functions and disengage the PTO. Snap tamper cap into position over the jam nut. The break away clip will be destroyed if the cap is removed.

Chapter 3 - Assembly Drawings

Base Assembly - PN 41826

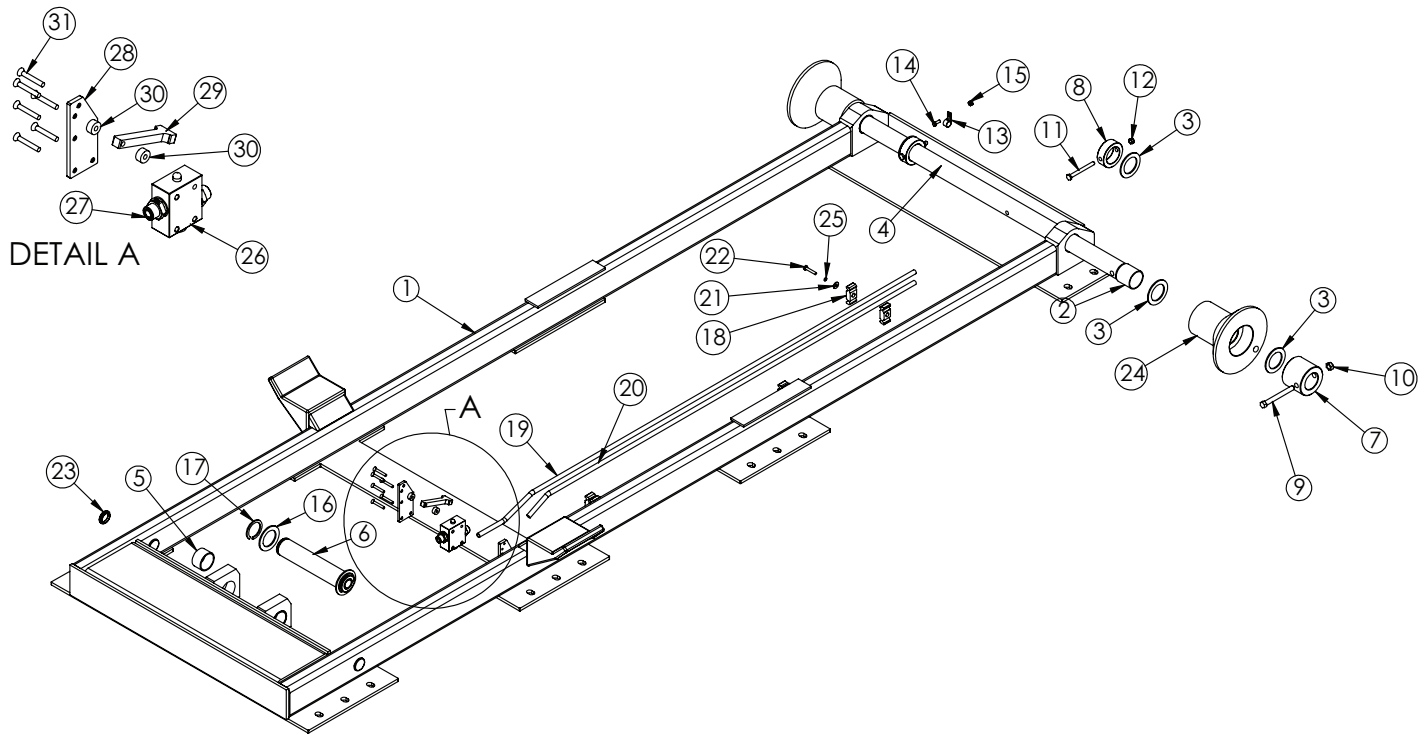

PN 41826

ITEM	PART	DESCRIPTION	QTY.	ITEM	PART	DESCRIPTION	QTY.
1	33338	BASE 84-10 FLEX 36	1	16	0427	MACHY WASHER 2.00ID 10GA	2
2	4381	BUSHING 32DXR32 2.00X2.00 GARLOCK	2	17	0108	SNAP RING 2.00 7200-200	2
3	1546	THRUST WASHER 2.01DIA UHMW .12THK	6	18	8622	CLAMP HOSE/TUBE AG-2	6
4	41774ZP	PIN 2.00X49.88	1	19	71948	TUBE ASM 0.50 84-10 FLEX TILT RETRACT YZ	1
5	23699	BUSHING 32DXR20 2.00X1.25	2	20	71949	TUBE ASM 0.50 84-10 FLEX TILT EXTEND YZ	1
6	33741ZP	PIN 2.00X10.19 SR	1	21	0340	WASHER 0.25 FLAT	3
7	0015PC	COLLAR 2.01X3.50X2.88	2	22	0220	CAP SCR 0.25-20 X 1.50 HHGR5	3
8	22764PC	COLLAR 2.01X3.00X1.00 W/HOLE	2	23	19112	PLUG PLASTIC CCF1.50-10-14	4
9	0507	CAP SCR 0.50-13X4.50 HHGR5	2	24	41776PC	ROLLER 2.00X4.00X3.81X8.00 PWDRCT YEL	2
10	C6106	NUT 0.50-13 HHGR5 NYLOC	2	25	0521	WASHER 0.25 LOCK	3
11	0532	CAP SCR 0.38-16X3.75 HHGR5	2	26	53853	VALVE PLUNGER VILLA HYD NORMALLY CLOSED	1
12	0347	NUT 0.38-16 HH NYLOC	2	27	57735	FTG 8-8 MBSPP-MFS STRAIGHT	2
13	C0078	CLAMP 0.38 BLK VINYL	1	28	77784	PLATE MNT BRKT STOP SYSTEM CS HOLES	1
14	0479	CAP SCR 0.25-20X0.75 HHGR5	1	29	70293	LEVER PLUNGER VALVE FINGER	1
15	0333	NUT 0.25-20 HHGR5 NYLOC	1	30	70294	COLLAR 0.28X0.75X0.38 UHMW	2
				31	77785	CAP SCR 0.25-20X1.75 FHS	6

Dump Assembly - PN 33339

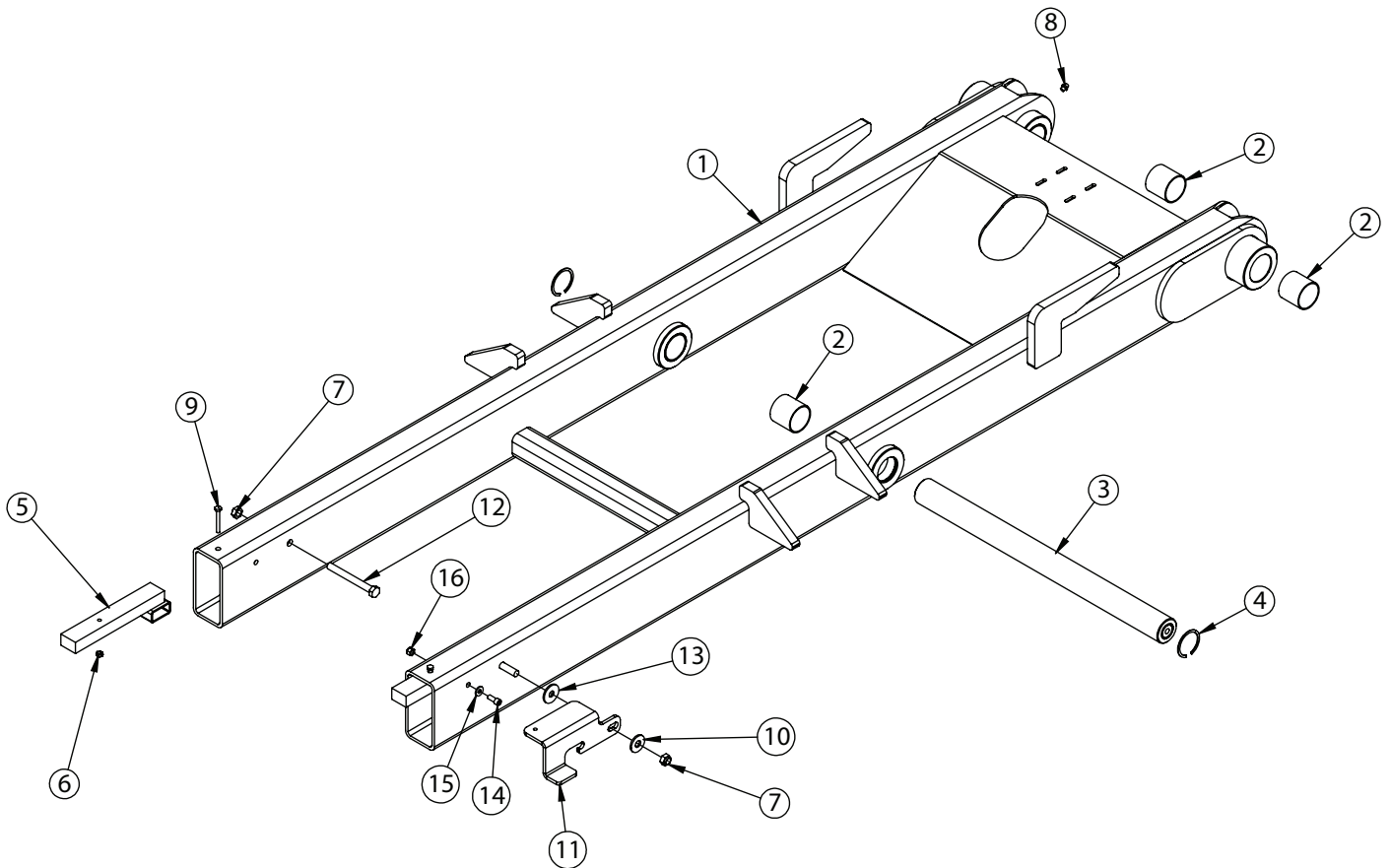

PN 33339

ITEM	PART	DESCRIPTION	QTY.
1	33340	DUMP 84-10 FLEX 36	1
2	4381	BUSHING 32DXR32 2.00X2.00 GARLOCK	6
3	22227ZP	PIN 2.00X25.25	1
4	2257	SNAP RING INSIDE 2.00	2
5	23301PC	TAB LOADER BREAK AWAY	2
6	0333	NUT 0.25-20 HHGR5 NYLOC	2
7	C6106	NUT 0.50-13 HHGR5 NYLOC	2
8	c1592	ZERK 1/8 NPT STRAIGHT	2
9	0481	CAP SCR 0.25-20X2.00 HHGR5	2
10	0352	WASHER 0.50 USS FLAT ZINC	1
11	65135	LEVER PLUNGER VALVE FORMED	1
12	0507	CAP SCR 0.50-13X4.50 HHGR5	2
13	C4516	WASHER 0.56IDX1.50ODX0.13 THK NYLON	1
14	38263	CAP SCR 0.31-18X0.75 SH	1
15	0340	WASHER 0.25 USS FLAT ZINC	1
16	0342	NUT 0.31-18 HHGR5 NYLOC	1

Secondary Assembly - PN 33341

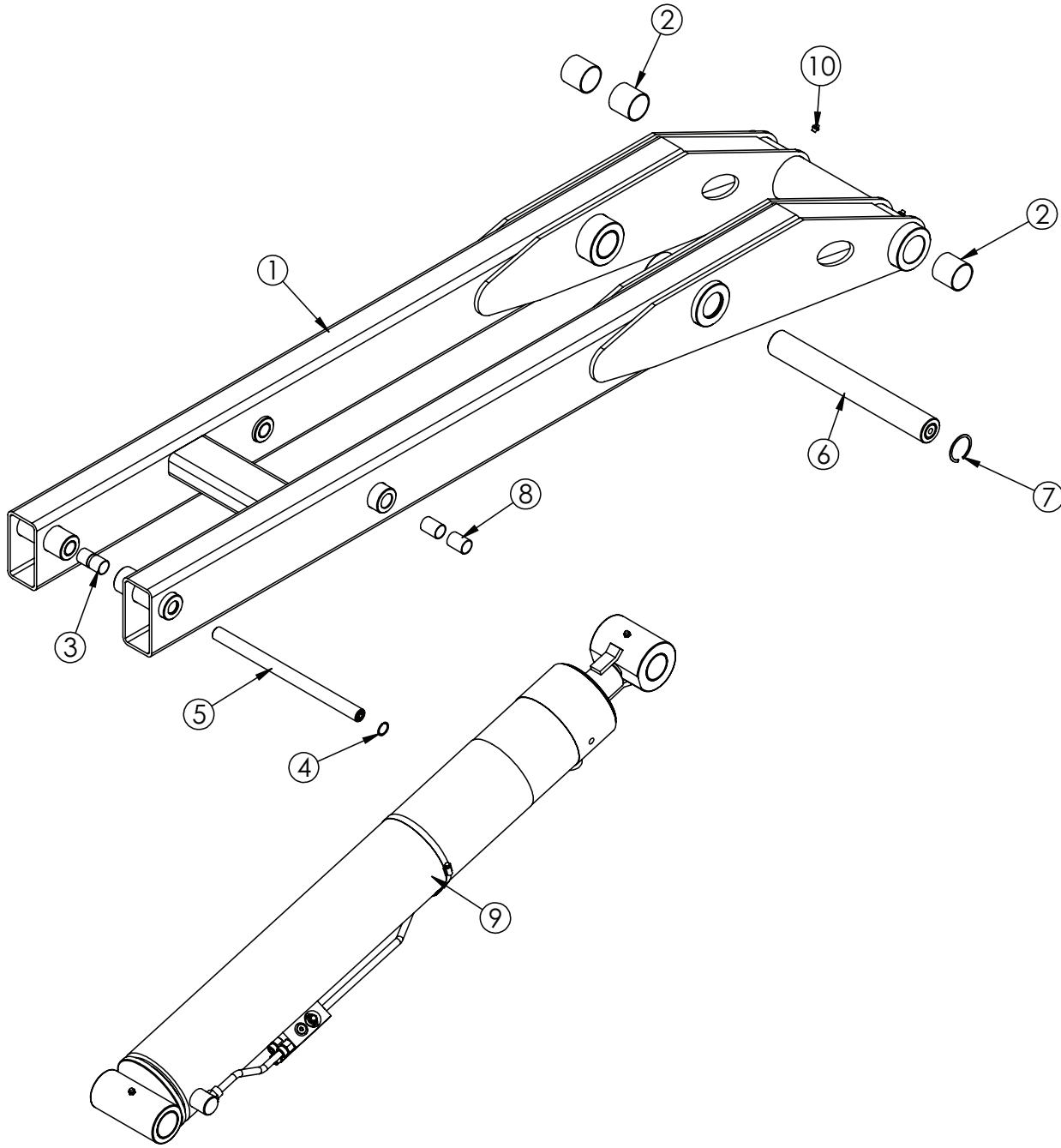

PN 33341

ITEM	PART	DESCRIPTION	QTY
1	33342	SECONDARY 84-10 FLEX 36	1
2	4381	BUSHING 32DXR32 2.00X2.00 GARLOCK	6
3	0069	BUSHING QSI-1618-16	4
4	3875	SNAP RING 1.00 INTERNAL	2
5	22285ZP	PIN 1.00X15.00	1
6	22286ZP	PIN 2.00X16.00	1
7	2257	SNAP RING INSIDE 2.00	2
8	0068	BUSHING QSI-1618-24	4
9	33404	CYLINDER ASM 5.50X40.13	1
10	c1592	ZERK 1/8 NPT STRAIGHT	2

Tilt Assembly - PN 33049

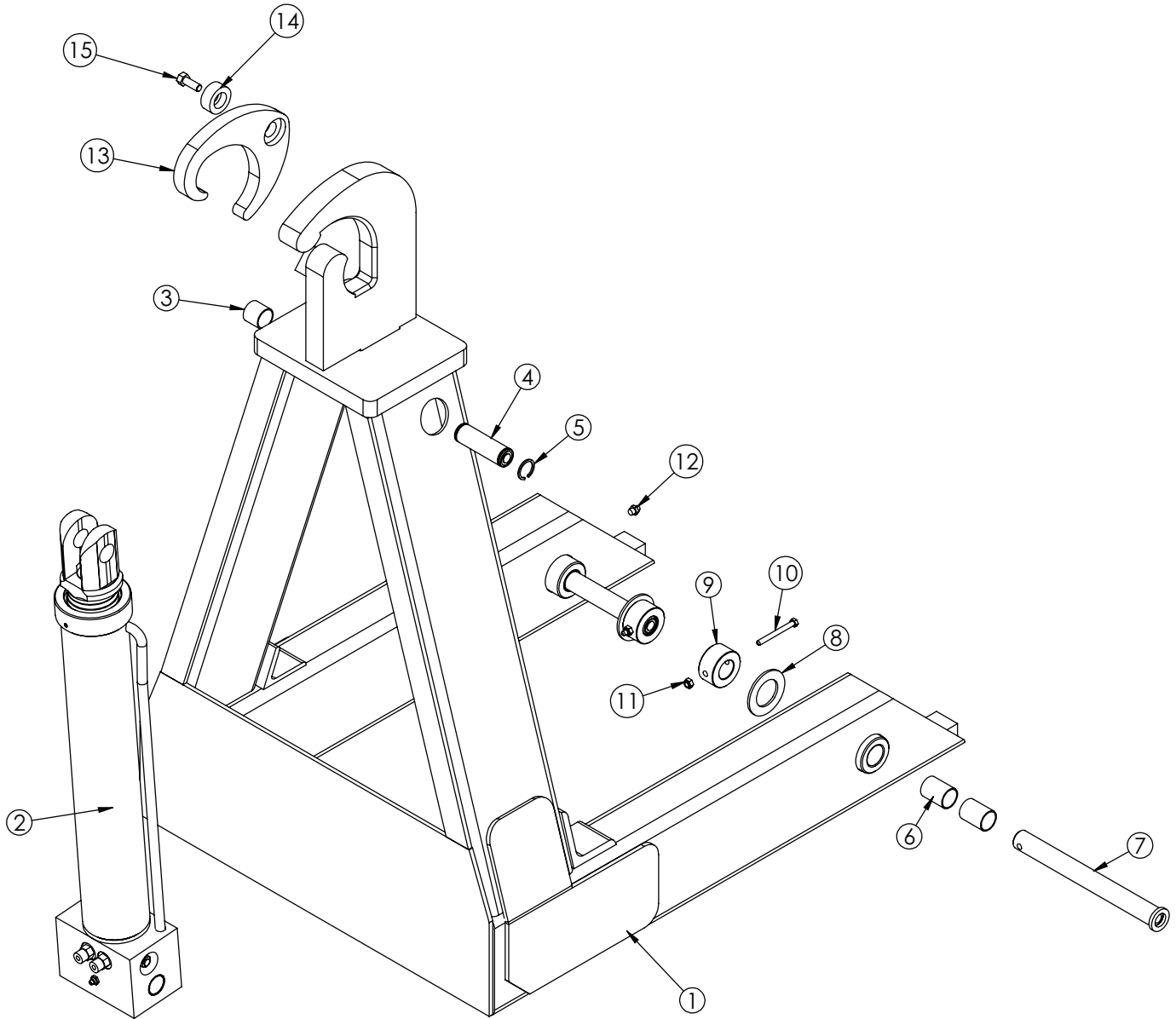

PN 33049

ITEM	PART	DESCRIPTION	QTY
1	33050	TILT FLEX 36	1
2	23460	CYLINDER ASM 3.00X17.00	1
3	0069	BUSHING QSI-1618-16	1
4	4912ZP	PIN 1.00X3.25 SR	1
5	0110	SNAP RING 1.00 ID 7200-100	2
6	0068	BUSHING QSI-1618-24	4
7	33103ZP	PIN WLDMT 1.00X9.81	2
8	d0419	THRUST WASHER	2
9	33104PC	COLLAR 1.03X2.00X1.00	2
10	0339	CAP SCR 0.25-20X2.50 HHGR5	2
11	0333	NUT 0.25-20 HHGR5 NYLOC	2
12	c1592	ZERK 1/8 NPT STRAIGHT	2
13	0295PC	LATCH 12,000#	1
14	14672	PIN CAP 0.44X1.50X0.63	1
15	9714	CAP SCR 0.38-16X1.00 SS	1

Optional Tall Tilt Assembly - PN 35032

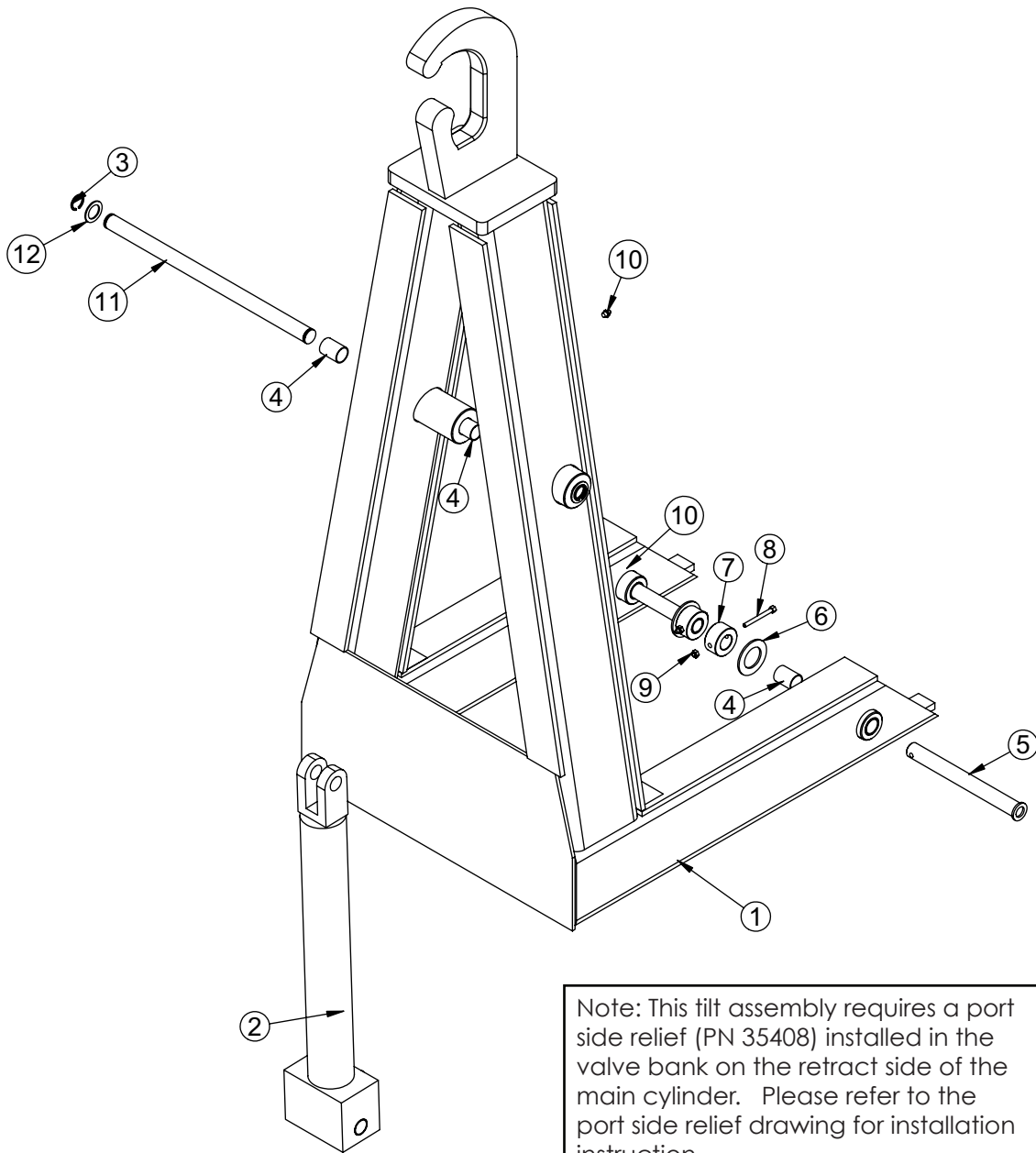

Note: This tilt assembly requires a port side relief (PN 35408) installed in the valve bank on the retract side of the main cylinder. Please refer to the port side relief drawing for installation instruction.

PN 35032

ITEM	PART	DESCRIPTION	QTY.
1	35033	TILT FLEX 36 54HH	1
2	35169	CYLINDER ASM 3.00X10.00	1
3	0110	SNAP RING 1.00 ID 7200-100	2
4	0068	BUSHING QSI-1618-24	8
5	33103	PIN WLDMT 1.00X10.50	2
6	D0419	THRUST WASHER	2
7	33104	COLLAR 1.03X2.00X1.00	2
8	0339	CAP SCR 0.25-20X2.50 HHGR5	2
9	0333	NUT 0.25-20 HHGR5 NYLOC	2
10	c1592	ZERK 1/8 NPT STRAIGHT	4
11	35066	PIN 1.00X18.38 SR	1
12	0867	MACHY WASHER 1.00ID 14GA	2

Main Cylinder Assembly - PN 33404

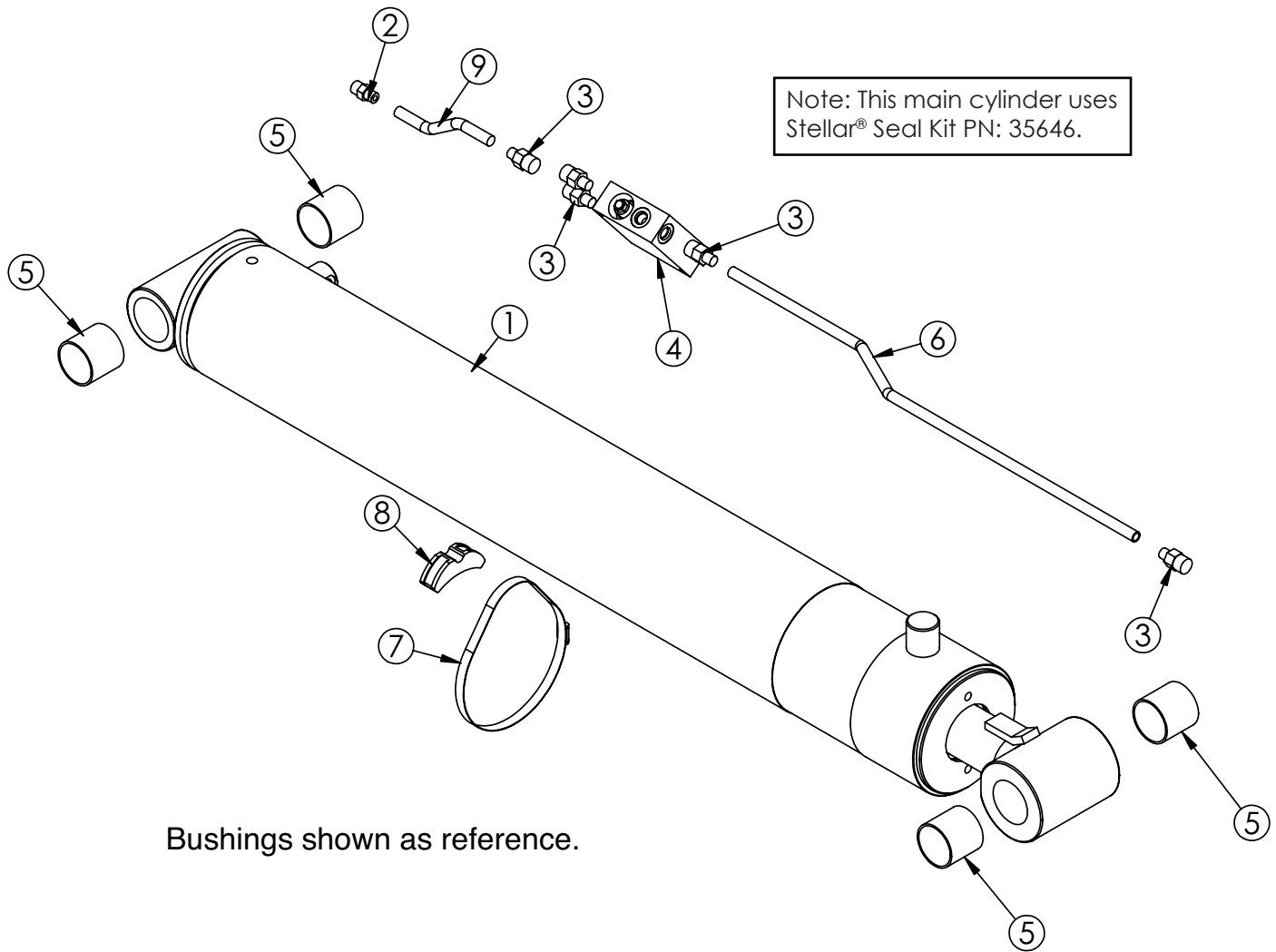

PN 33404

ITEM	PART	DESCRIPTION	QTY.
1	33405	CYLINDER 5.50X40.00	1
2	0279	FTG ADAPT 6-F5OLO-S	1
3	D1290	FTG ADAPT 8-6 F5OLO-S	5
4	15822	MANIFOLD DOUBLE T11A 5000 PSI	1
5	4381	BUSHING 32DXR32 2.00X2.00 GARLOCK	4
6	33744	TUBE ASM 0.50X27.75	1
7	19369	HOSE CLAMP 4.13-7.00 5416K38	1
8	18701	CLAMP PORT TUBE ZR518	1
9	16256	TUBE ASM 0.50X6.75 MAIN CYL 60-10-8	1

Tilt Cylinder Assembly - PN 23460

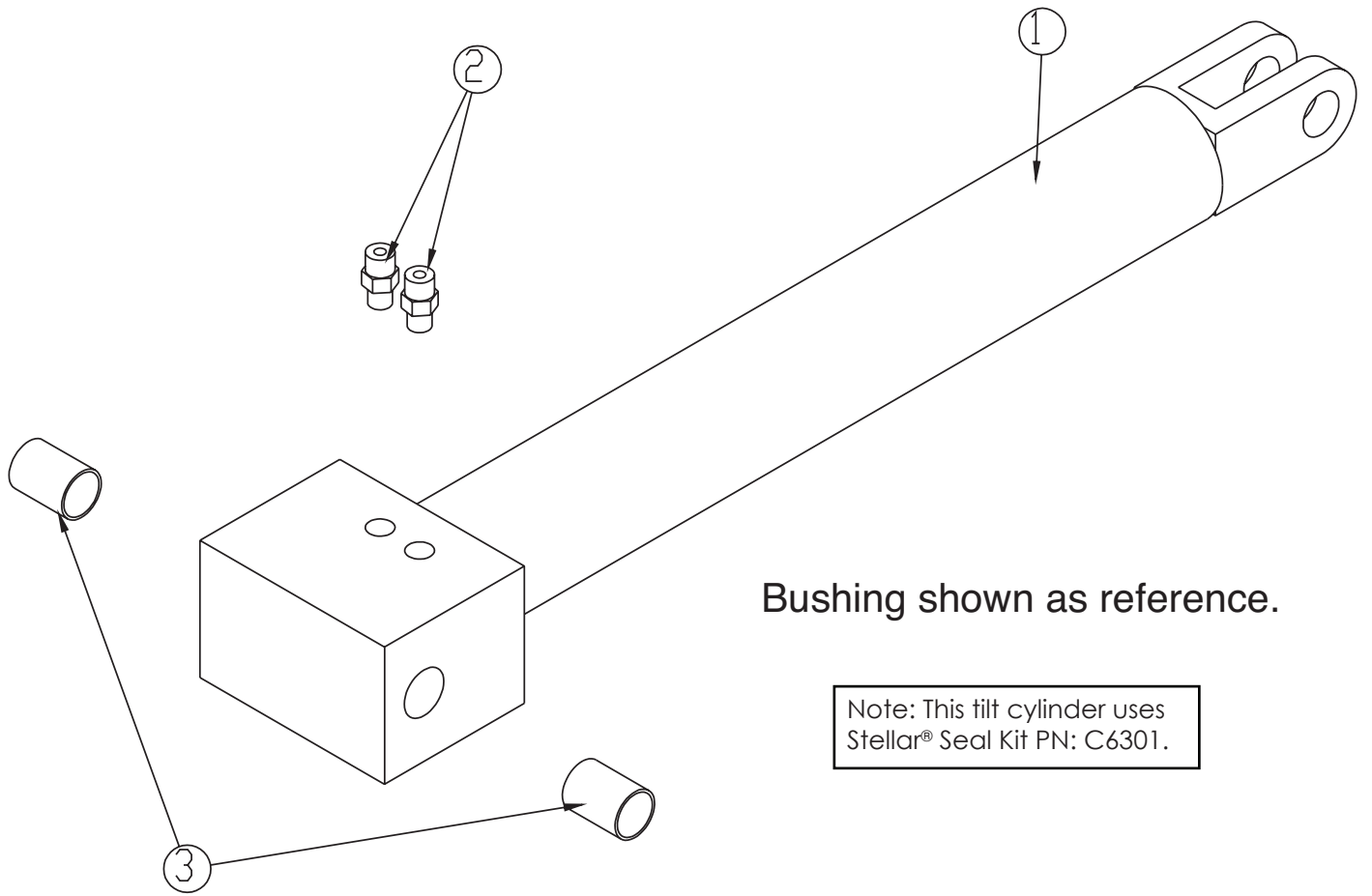

Bushing shown as reference.

Note: This tilt cylinder uses Stellar® Seal Kit PN: C6301.

PN 23460

ITEM	PART	DESCRIPTION	QTY.
1	3767	CYLINDER 3.00X17.00	1
2	0279	FTG ADAPT 6-F5OLO-S	2
3	0068	BUSHING QSI-1618-24	2

25 Gallon Reservoir Assembly - PN 35883

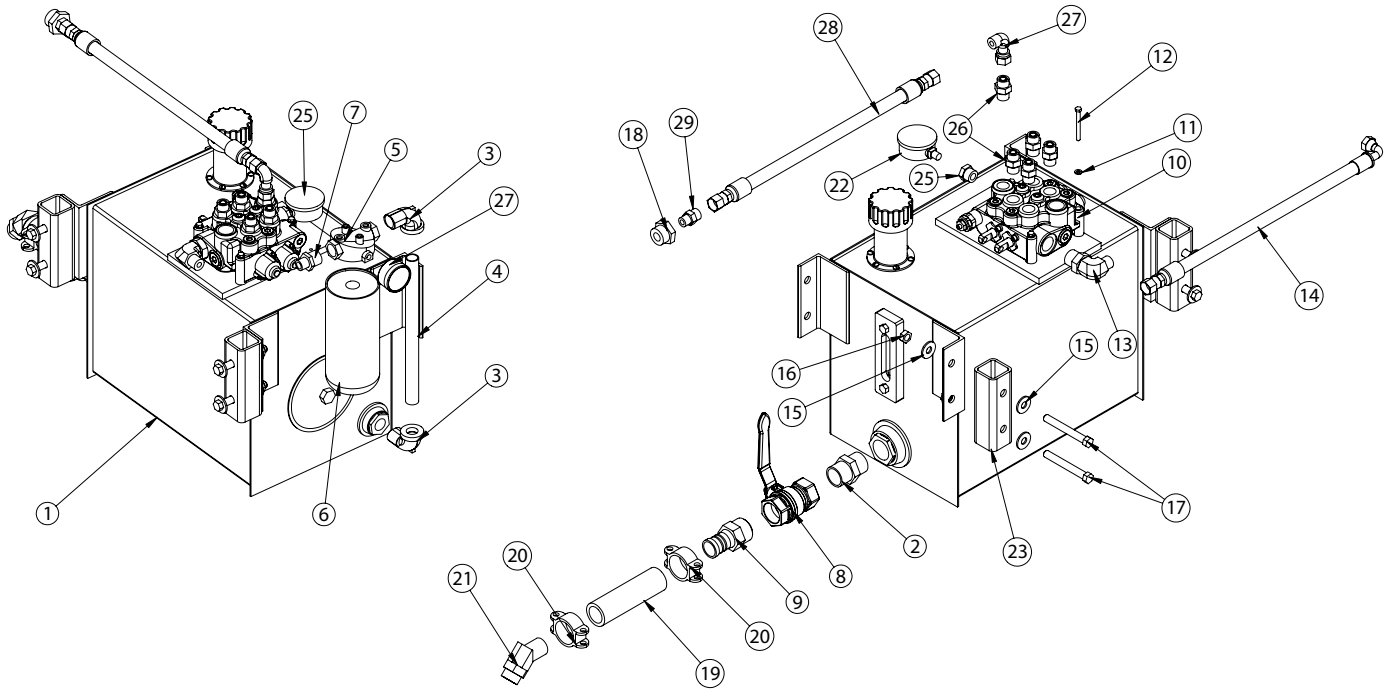

PN 35883

ITEM	PART	DESCRIPTION	QTY.	ITEM	PART	DESCRIPTION	QTY.	ITEM	PART	DESCRIPTION	QTY.
1	26455	RSRVR ASM 10GAL K MODEL	1	13	C4227	FTG MF/MSTR 90 8-12 C5OLO-S	1	25	25630	FTG ADAPT 10-1/4 F5OG	1
2	1115	FTG NIPPLE HEX MALE 0101-20-20	1	14	26731	HOSE 0.50(381-JC-J9-8-8-8-18-0)	1	26	C2252	FTG ADAPT 8-10-F5OLO-S	5
3	c2242	ST EL 0.75 90 DEG BLK	2	15	0352	WASHER 0.50 USS FLAT ZINC	8	27	C2376	FTG ADAPT 8-C6LO-S	1
4	3320	NIPPLE 0.75X12.00 PIPE	1	16	C6106	NUT 0.50-13 HHGR5 NYLOC	4	28	31676	HOSE 0.50(471TC-JC-JC-8-8-8-120)	1
5	c6226	FILTER HEAD	1	17	0506	CAP SCR 0.50-13X4.00 HHGR5	4	29	1554	FTG ADAPT 8-F5OLO-S	1
6	C6229	FILTER LARGE AE-10L	1	18	D0549	FTG ADAPT 16-8 F5OG5-S	1				
7	C6014	FTG ADAPT 8-12 FOLO-S	1	19	17767	HOSE SUCT 1.25 10FT	1				
8	C5511	VALVE BALL 1.25	1	20	C1123	HOSE CLAMP 88 DB-20	2				
9	C2282	FTG 1.25 NPT TO 1.25 BARB	1	21	C4747	NIPPLE O'RING 45 4603-20-16	1				
10	24611	VB 2-SECTION VDM8	1	22	10094	GAUGE OIL LF 2.5" 0-500 BM	1				
11	0521	WASHER 0.25 LOCK	3	23	9892	SPACER TANK MOUNTING 10 GAL	2				
12	0339	CAP SCR 0.25-20X2.50 HHGR5	3	24	16145	GAUGE PRES FILTER SERVICE CI20	1				

Valve Bank Parts Drawing

