

**Sanitary
Equipment
Co., Inc.**

SALES PARTS SERVICE

DO IT RIGHT THE FIRST TIME

Committed to delivering equipment that meets immediate needs and exceeds expectations for years to come.

INDUSTRY LEADING EQUIPMENT



SHOP OEM PARTS AT SANITARYEQUIPMENT.COM

25 Industry Dr
West Haven, CT 06516
(203) 933-9599

1140 Turnpike St., Unit 3&4
Stoughton, MA 02072
(855) 373-7324

CONTRACTOR MODELS

MD100 & MD200 Bailment pool style dump bodies built as turnkey units for quick & easy installation and quick lead times

MD¹⁰⁰



MD²⁰⁰



FLOOR

- Available dimensions: 9' / 9.5' / 11' / 11.5' / 12'
- Material: 10 gauge Brinell 150
- Side to floor angle 22° with fixed side or flat floor with drop sides
- Outside width 99"
- Four "D"-rings installed (one in each corner)

UNDERSTRUCTURE

- Crossmemberless structure
- Longmember configuration: formed 8"
- Longmember material: 3/16" Brinell 150
- Adjustable mud flap brackets mounted at rear

SIDE

- Available dimensions: 14"
- Material: 10 gauge Brinell 150
- Available configurations: fixed or drop sides
- Open profile top rail
- Drop side mounted to edge of body, closes without preparatory cleanup

HEADSHEET AND CAB SHIELD

- Material: 10 gauge Brinell 150
- 10" cab shield available at 53" or 61" height
- Headsheet configurations: flat for underbody hoist with 4" subframe
- Window slots in headsheet
- Optional manual tarp

TAILGATE

- Available dimensions: 19"
- Material: 10 gauge Brinell 150
- Double acting tailgate
- Spreader chains included

HOIST CONFIGURATION

- Patent Pending Brandon Underbody hoist with 4" bolt-on sub-frame for quick installation (brackets provided)
- Optional double acting electric power pack including oil tank and controls
- Optional electrical breaker and cables

FINISHING

- Sandblasted, primed, and painted with black heavy-duty epoxy

FLOOR

- Available dimensions: 8'6" to 12'
- Material: 10 gauge Brinell 150, 3/16" Brinell 150, 3/16" Brinell 450
- Side to floor angle 22° with fixed side or flat floor with drop sides
- Outside width: 99"
- Four "D"-rings installed (one in each corner)

UNDERSTRUCTURE

- Crossmemberless structure
- Longmember configuration: formed 8"
- Longmember material: 3/16" Brinell 250
- Adjustable mud flap brackets mounted at rear

SIDE

- Available dimensions: 14" or 16"
- Material: 10 gauge Brinell 150, 3/16" Brinell 150, 3/16" Brinell 250
- Available configurations: fixed or drop sides
- Open profile top rail standard
- Drop side mounted to edge of body, closes without preparatory cleanup

HEADSHEET AND CAB SHIELD

- Material: 10 gauge Brinell 150, 3/16" Brinell 150, 3/16" Brinell 250
- 10" cab shield installed – variable heights from 49" to 61"

- Headsheet configurations: flat for underbody hoist

- Optional window slots in headsheet
- Optional ¾" light holes for cab shield
- Optional manual tarp

TAILGATE

- Available dimensions: 19" or 21"
- Material: 10 gauge Brinell 150, 3/16" Brinell 150, 3/16" Brinell 250
- Standard manual double acting tailgate
- Spreader chains included
- Optional bolt-on single centered coal door

HOIST CONFIGURATION

- Patent Pending Brandon Underbody hoist with 4" bolt-on sub-frame for quick installation (brackets provided)
- Optional double acting electric power pack including oil tank and controls
- Optional electrical breaker and cables (underbody hoist option only)

FINISHING OPTIONS

- Sandblasted and primed
- Sandblasted, primed, and painted with heavy-duty epoxy (various colors available)

MD300 & MD400SS

Customized style dump bodies to meet specific client needs with many various options, materials and thicknesses

MD300

MD400SS



FLOOR

- Available dimensions: 8' 6" to 18'
- Material: 10 gauge Brinell 150 (up to 12'), 3/16" Brinell 150, 3/16" Brinell 450, 1/4" Brinell 450
- Side to floor angle 22° with fixed side or flat floor with drop sides
- Outside width: 99"
- Optional 96" (fixed sides)
- Four "D"-rings installed (one in each corner)

UNDERSTRUCTURE

- Crossmemberless structure
- Longmember configuration: formed or I-beam 6", 8" or 10"
- Longmember material: 3/16" Brinell 250
- Adjustable mud flap brackets mounted at rear

SIDE

- Available dimensions: 14" to 18" (drop sides), 14" to 20" (fixed sides)
- Material: 10 gauge Brinell 150, 3/16" Brinell 150, 3/16" Brinell 250
- Available configurations: fixed or drop sides
- Open profile top rail standard optional closed profile
- Drop side mounted to edge of body, closes without preparatory cleanup
- Optional wood board brackets
- Standard removal center post starting over 12' in length with double drop sides

HEADSHEET AND CAB SHIELD

- Material: 10 gauge Brinell 150, 3/16" Brinell 150, 3/16" Brinell 250

- 10" to 18" cab shield installed or loose – variable heights
- Headsheet configurations: flat for underbody hoist or recessed for front mount telescopic
- Optional window slots in headsheet
- Optional 3/4" light holes for cab shield
- Optional manual tarp

TAILGATE

- Available dimensions: 19" to 25"
- Material: 10 gauge Brinell 150, 3/16" Brinell 150, 3/16" Brinell 250
- Standard manual double acting tailgate with optional air tailgate latch system
- Spreader chains included
- Optional bolt-on single centered coal door

HOIST CONFIGURATION

- Choice of Patent Pending Brandon underbody hoist with 4" bolt-on sub-frame for quick installation (Brackets provided) for 12' and under in length or front mount telescopic hoist (single or double acting) for 8' 6" to 18' in length
- Optional double acting electric power pack including oil tank and controls (underbody hoist option only)
- Optional electrical breaker and cables (underbody hoist option only)
- Optional front mount hoist installation kit

FINISHING OPTIONS

- Sandblasted and primed
- Sandblasted, primed, and painted with heavy-duty epoxy (various colors available)

FLOOR

- Available dimensions: 8' 6" to 16'
- Material: 10 gauge SS 304 or 201 (up to 12'), 3/16" SS 304 or 201, 3/16" Brinell 450, 1/4" Brinell 450
- Side to floor angle 22° with fixed side or flat floor with drop sides
- Outside width 99"
- Four zinc plated "D"-rings installed (one in each corner)

UNDERSTRUCTURE

- Crossmemberless structure
- Longmember configuration: formed or steel I-beam 6", 8" or 10" (formed longmembers mandatory with Brandon hoist)
- Longmember material: 3/16" Brinell 250 or 3/16" SS 304 or 201
- Adjustable mud flap brackets mounted at rear (steel or SS)

SIDE

- Available dimensions: 14" to 18" (drop sides), 14" to 20" (fixed sides)
- Material: 10 gauge SS 304 or 201, 3/16" SS 304 or 201
- Available configurations: fixed or drop sides
- Open profile top rail standard optional closed profile
- Drop side mounted to edge of body, closes without preparatory cleanup
- Optional SS wood board brackets
- Standard removal center post starting over 12' in length with double drop sides

HEADSHEET AND CAB SHIELD

- Material: 10 gauge SS 304 or 201, 3/16" SS 304 or 201

- 10" to 18" one piece cab shield installed or two pieces when not installed – variable heights available

- Headsheet configurations: flat for underbody hoist or recessed for front mount telescopic
- Optional window slots in headsheet
- Optional 3/4" light holes for cab shield
- Optional manual tarp

TAILGATE

- Available dimensions: 19" to 25"
- Material: 10 gauge SS 304 or 201, 3/16" SS 304 or 201
- Standard manual double acting tailgate with optional air tailgate latch system
- Zinc plated spreader chains included
- Optional SS bolt-on single centered coal door

HOIST CONFIGURATION

- Choice of Patent Pending Brandon underbody hoist with 4" bolt-on sub-frame for quick installation (Brackets provided) for 12' and under in length or front mount telescopic hoist (single or double acting) for 8' 6" to 16' in length
- Optional double acting electric power pack including oil tank and controls (underbody hoist option only)
- Optional electrical truck battery breaker and cables (underbody hoist option only)
- Optional front mount hoist installation kit

FINISHING

- Acid wash (up to 14') or glass bead blasting
- Underneath painted black

FLEX-SYSTEM



FLEX-SYSTEM™

The next generation of dump body technology.

Our patented, bolt-on system allows your dump body to be modular, adaptable and flexible without compromising durability or weight.

FLEX-BODY™

Stronger and lighter than a typical body, giving you an added advantage in the field.

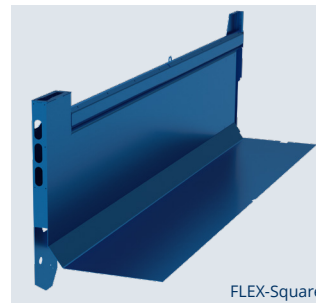

FLEX-Square

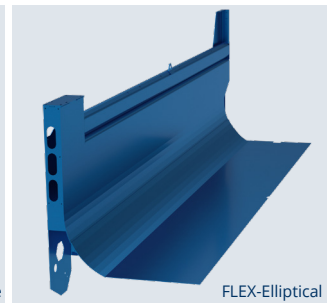

FLEX-Elliptical

FLEX-GATE™

The first universal dump tailgate. Three interchangeable gate configurations that can be switched at any time, without grinding, welding or painting.



Single Action

Tailgate opens as bed is raised for dumping



Internal High Lift

Pneumatic operation to lift the tailgate out of the way for dumping



Swing / Barn Door

Manually swing tailgate out of the way and attach to side of body for dumping

FLEX-PARTS™

Many bolt-on options that can be added or switched out at any time - even after the body is painted.



Cab Shield

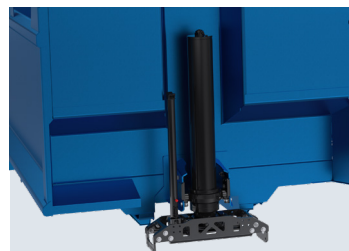

Cradle



Coal Door(s)



Rear Hinge

VOCATION - CONSTRUCTION - MUNICIPAL MODELS

FLEX-Body (Bolt-on technology)

14' to 22' in 6" increments

Offered in:

- FLEX-Square
- FLEX-Elliptical

Your choice of material thickness in Hardox 500 Tuf Steel



INSIDE WIDTH	88"	OUTSIDE WIDTH	100"
--------------	-----	---------------	------

FLEX-BODY™	AVAILABLE DIMENSIONS	MATERIAL
FLOOR	14' to 22' (6" increments)	3/16" or 1/4" Brinell 500 (Hardox 500 Tuf)
SIDES	48" to 66" (6" increments)	5/32", 3/16" or 1/4" Brinell 500 (Hardox 500 Tuf)
TAILGATE	48" to 66"	1/4" Brinell 500 (Hardox 500 Tuf)
FRONT	Customized to truck	5/32", 3/16" or 1/4" Brinell 500 (Hardox 500 Tuf)
LONGMEMBERS	8" or 10" Formed long sills	3/16" or 1/4" Brinell 250
CAB SHIELD	18" to 36" (Bolt-on)	10 gauge 150 Brinell

* Standard bolt-on top rail with optional open profile top rail

Traditional Body (Welded)

10' to 22' in 6" increments

Offered in:

- Traditional Square
- Traditional Elliptical

Your choice of material thickness in Brinell 450 Steel



INSIDE WIDTH	85" or 88"	OUTSIDE WIDTH	96" or 100"
--------------	------------	---------------	-------------

TRADITIONAL WELDED BODY	AVAILABLE DIMENSIONS	MATERIAL
FLOOR	10' to 22' (6" increments)	3/16" or 1/4" Brinell 450 or Hardox 500 Tuf
SIDES	24" to 66" (6" increments)	5/32", 3/16" or 1/4" Brinell 450 or Hardox 500 Tuf
TAILGATE	32" to 66"	3/16" or 1/4" Brinell 450 or Hardox 500 Tuf
FRONT	Customized to truck	5/32", 3/16" or 1/4" Brinell 450 or Hardox 500 Tuf
LONGMEMBERS	6", 8" or 10" formed	3/16" or 1/4" Brinell 250
CAB SHIELD	18" to 36" (Welded or bolt-on)	10 gauge or 3/16" 150 Brinell

* Standard bolt-on top rail with optional open profile top rail

VOCATION - CONSTRUCTION - MUNICIPAL MODELS

Custom Body

10' to 22' in 1" increments

Offered in:

- Custom Square
- Custom Elliptical

Your choice of material thickness & steel grades plus options not available on other models



INSIDE WIDTH	85" or 88"	OUTSIDE WIDTH	96" or 100"
--------------	------------	---------------	-------------

CUSTOM BODY	AVAILABLE DIMENSIONS	MATERIAL
FLOOR	8' to 22' (1" increments)	Mild Steel: 3/16" Brinell 150 Hardened Steel: 3/16" or 1/4" Brinell 250 • 3/16" or 1/4" Brinell 450 Hardox 500 Tuf: 5/32", 3/16" or 1/4"
SIDES	24" to 66" (1" increments)	Mild Steel: 10 gauge or 3/16" Brinell 150 Hardened Steel: 3/16" or 1/4" Brinell 250 • 3/16" or 1/4" Brinell 450 Hardox 500 Tuf: 5/32", 3/16" or 1/4"
TAILGATE	24" to 66" (1" increments)	Mild Steel: 3/16" Brinell 150 Hardened Steel: 3/16" or 1/4" Brinell 250 • 3/16" or 1/4" Brinell 450 Hardox 500 Tuf: 5/32", 3/16" or 1/4"
FRONT	Customized to truck	Mild Steel: 10 gauge or 3/16" Brinell 150 Hardened Steel: 3/16" or 1/4" Brinell 250 • 3/16" or 1/4" Brinell 450 Hardox 500 Tuf: 5/32", 3/16" or 1/4"
LONGSILLS	6", 8" or 10", formed or I-Beams	3/16" or 1/4" Brinell 250
CAB SHIELD	12", 18", 24", 30", 36", 42" or 48"	10 gauge or 3/16" Brinell 150

Stainless Body

10' to 20' in 6" increments

Offered in:

- Square Stainless
- Elliptical Stainless

Your choice of material thickness and grade in either 304 or 201 Stainless with optional steel floor & longsills



INSIDE WIDTH	85" or 88"	OUTSIDE WIDTH	96" or 100"
--------------	------------	---------------	-------------

STAINLESS BODY	AVAILABLE DIMENSIONS	MATERIAL
FLOOR	10' to 20'	Stainless: 3/16" or 1/4" SS201/304 Hardened Steel: 3/16" Brinell 250 (seamed) • 3/16" or 1/4" Brinell 450
SIDES	24" to 60"	Stainless: 10 gauge, 3/16" or 1/4" SS201/304
TAILGATE	24" to 60"	Stainless: 10 gauge, 3/16" or 1/4" SS201/304
FRONT	Customized to truck	Stainless: 10 gauge, 3/16" or 1/4" SS201/304
LONGSILLS	6", 8" or 10", formed or I-Beam	Stainless: 3/16" or 1/4" SS201/304 Hardened Steel: 3/16" or 1/4" Brinell 250
CAB SHIELD	12", 18", 24", 30" or 36"	Stainless: 7 or 10 gauge SS201/304

Disaster Relief Body

For extreme applications, including demolition, waste management (white days), scrap steel hauling, rendering and disaster relief clean up. Built for front or rear grapple systems available as a front mount dumping or as a non-dumping body.



Offered in:

- Your choice of material thickness in Brinell 450
- Dumping or Non-Dumping
- Flat front •Flat rear (no door)

INSIDE WIDTH	92 1/2"	OUTSIDE WIDTH	102"
--------------	---------	---------------	------

DISASTER BODY	AVAILABLE DIMENSIONS	MATERIAL
FLOOR	16' to 26' (6" increments)	1/4" or 3/16" Brinell 450
SIDES	60" to 96" (6" increments)	1/4" or 3/16" Brinell 450
TAILGATE	60" to 96" (6" increments)	1/4" or 3/16" Brinell 450
FRONT	48", 60", or 96"	1/4" or 3/16" Brinell 450
LONGMEMBERS	8" or 10"	1/4" or 3/16" Brinell 250
CAB SHIELD	24" to 48"	7g or 10g - 150 Brinell

*BDM-Mild Steel model available upon request.

Chipper Body

Built with Hardox HiAce, the new ace in corrosion-resistant wear steel for acidic environments. Using this hardened steel gives you the advantage of product longevity and protects your body even if paint is scratched.



Offered in:

- "L" Shape with saddle-style front toolbox
- Square

OUTSIDE WIDTH	96"
---------------	-----

CHIPPER BODY	AVAILABLE DIMENSIONS	MATERIAL
BODY	11' x 66" x 30" (other configurations available upon request)	4mm (5/32") Hardox 450 HiAce
LONGMEMBERS	8" formed	3/16" Brinell 250
BRANDON UNDERBODY HOIST	UH51 or UH60	-

TRAILER MODELS

Full Frame Replacement Trailer

In your choice of steel and thickness



INSIDE WIDTH	87 1/2" or 89 1/2"	OUTSIDE WIDTH	96" or 99"
--------------	--------------------	---------------	------------

TRAILER	AVAILABLE DIMENSIONS	MATERIAL
FLOOR	16' to 32'	3/16" or 1/4" Brinell 450 • Hardox 500 Tuf
SIDES	54" to 72"	5/32", 3/16" or 1/4" Brinell 450 • Hardox 500 Tuf
TAILGATE	54 to 66"	1/4" or 3/16" Brinell 450 • Hardox 500 Tuf
DOG HOUSE FRONT	-	5/32", 3/16" or 1/4" Brinell 450
LONGSILLS	-	3/16" or 1/4" Brinell 450
HOIST ATTACHMENT	Pin-to-pin hoist	-

Hooklift Bodies

All of our bodies are available as a Hooklift body.



Brandon Underbody Hoist

Patent Pending Hoist Quick Attach System

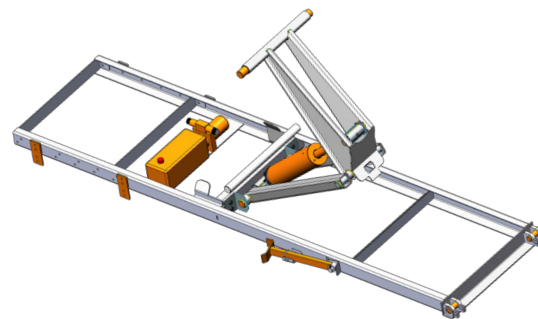

Part Number	Description	Sub-frame	Safety Prop	5" Cylinder	Pump & Motor	Oil Tank	Wires & Connectors	Breaker	Weight (lbs)
UH51SF	Sub-frame and hoist only	✓	✓	✓					575
UH51SF-PP	Same as above, plus electric over hydraulic power pack	✓	✓	✓	✓	✓			605
UH51SF-PPE	Same as above, plus electrical kit for truck battery	✓	✓	✓	✓	✓	✓	✓	609

STANDARD & CUSTOM AVAILABLE OPTIONS

FLEX-PARTS

- Bolt-on cab shield
- Bolt-on rear hinge (20-50 ton)
- Bolt-on front cradle (20 & 30-50 ton)
- Bolt-on reversible hoist blocks (20-30 ton & 40-50 ton)
- Bolt-on coal doors
- Bolt-on spreader kits
- Bolt-on safety door locks

FRONT

- Standard straight front mount recess (12" deep)
- Flat front for underbody hoist
- Flat front for outside front mount hoist (brackets installed)
- Sloped front for front mount hoist
- Dog House for Pin to Pin hoist
- Integrated front hydraulic tank
- Shovel bracket
- Hyva front mount cylinders
- Cradle & hoist blocks (5-50 ton)
- Front mount hoist installation kits (tank, cradle, blocks & rear hinge) (5-50 ton)

CAB SHIELDS

- 12" to 48"
- 10" extension
- Assembled or loose
- Narrow or full width
- Custom
- Light hole cut-outs (oval or round)
- LED & strobe lighting kits with marine & fire grade wiring harness
- Light hole cover

HOISTS

- Front mount telescopic
- Pin-to-pin
- Underbody

TARP SYSTEMS

- Electric tarps
- Air tarps
- Manual tarps
- Mesh or asphalt canvas

SIDES

- 1 piece sides (formed top rail & rub rail - no welds)
- Smooth sides
- Formed aerodynamic sides
- Tapered/sloped sides
- Vertical posts on select models
- Weld-on horizontal bracing on select models
- Box bracing on select models
- Inverted angle irons on select models
- Open profile top rail
- Non-removable bolt-on top rail
- Dirt shedding top rails
- Snow extension side board kit
- Steel side boards
- Single or double quick release drop sides for Contractor models
- Side light brackets

TAILGATE

- Standard sloped or straight gate
- Barn door / Swing tailgate
- Double acting tailgate
- High-lift tailgate
- Air internal rear post mounted system
- Asphalt tailgate/bumper (reverse taper)
- Light hole cut-outs (oval or round)
- LED & strobe lighting kits with marine & fire grade wiring harness
- Standard one-panel tailgate 2, 3 or 6 panels on select models (vertical or horizontal style available)
- Coal/material chutes (1, 2 or 3) standard or guillotine style
- Air or manual tailgate kit or combination of both systems
- Manual quick release tailgate system for Contractor models

REAR

- Flat bumper
- Asphalt aprons (8", 10", 12" or custom)
- Lighting bars
- Rear hinges (5-50 ton)
- 7 gauge 201/304 Stainless steel rear posts
- Sloped rear post with recessed hardware
- Scow ends

UNDER THE BODY

- 8", 10" or 12" formed longsills 6", 8" & 10" I-Beams or "C" channel (with or without support flange)
- Underbody hoist & sub-frame
- Brandon mud flaps (front & rear)
- Traditional heat kits (4" or 5" stainless steel)
- Thermal heat kits (4" or 5" stainless steel)
- Body prop mounted on cradle

PRE-INSTALL OPTIONS

- Paint on select models
- Pre-installed cab shield (front entrance clearance height needed)
- Pre-installed wiring & lighting kits (body & cab shield)
- Pre-installed cab shield lighting bars
- Pre-installed body prop & mud flap bracket kits
- Pre-installed tarp system (excluding canvas)

**Sanitary
Equipment
Co., Inc.**

SALES PARTS SERVICE

DO IT RIGHT THE FIRST TIME

Committed to delivering equipment
that meets immediate needs
and exceeds expectations
for years to come.

INDUSTRY LEADING EQUIPMENT



SHOP OEM PARTS AT SANITARYEQUIPMENT.COM

25 Industry Dr
West Haven, CT 06516
(203) 933-9599

1140 Turnpike St., Unit 3&4
Stoughton, MA 02072
(855) 373-7324