

TL-3 with 1824 TBS body shown, other body sizes & options available.

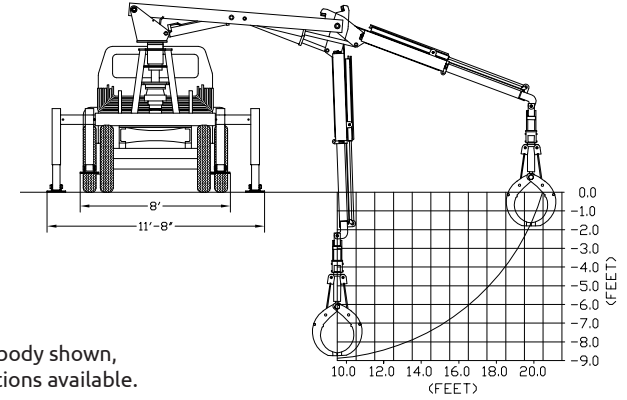

SYSTEM DESCRIPTION:

The model TL-3 Lightning Loader® is a grapple loader mounted to a chassis from behind the cab, equipped with Petersen's standard trash bucket at the end of the boom. The loader operates from a fixed platform located behind the chassis cab. CNG Capable.

LIFT CAPACITY

| Radius | Load Capacity |
|---------------|---------------|
| 10 ft. radius | 7,100 lbs. |
| 16 ft. radius | 4,400 lbs. |
| 20 ft. radius | 3,200 lbs. |

Note: Weight of attachment not subtracted from above listed lifting capacities. Trash bucket weighs 1,000 lbs. Capacities shown do not exceed 85% vehicle tipping moment (outriggers engaged, loader on firm, level ground.)

GENERAL SPECIFICATIONS

| | |
|--------------------------|-----------------|
| Reach | 20 ft. 7 inches |
| ⊗ Main Boom & Tip Boom | 16 ft. 7 inches |
| ⊗ Tip Extension | 4 ft. |
| Tare Weight (empty) | 23,000 lbs. |
| Outrigger Span | 11 ft. 8 in. |
| Dump Body Hoist Capacity | 23 tons |

RECOMMENDED CHASSIS (MINIMUM)

| | |
|-----------------------|---|
| Body Style | Conventional Cab |
| Cab-to-Axle Dimension | 168", 186", 192" |
| Front Axle Rating | 12,000 lbs. Minimum |
| Rear Axle Rating | 21,000 lbs. Minimum |
| GVW Rating | 33,000 lbs. Minimum |
| Frame | 1,500,000 RBM |
| Frame Thickness | 11/32" Minimum |
| Engine | 230 HP Diesel |
| Transmission | Automatic |
| Electrical | Remote engine & transmission connectors |

*Always contact Petersen Industries for specific chassis requirements

CONTROL OPTIONS:

Dual manual controls for outriggers and loader on both sides of the truck for accessibility and visibility come standard on this model. QUADSTICK® mechanically linked dual joystick controls (left) are also an available option on the TL-3 and stationary top mount controls (right).



SCAN TO
LEARN MORE

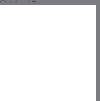

4000 SR 60 West
Lake Wales, FL 33859

1.800.930.LOAD (5623)



PETERSENIND.COM
Contact Us Today To Learn More