

# Specification Sheet

# RT655 SWEEPER

**Series RT655**

Sheet 1 of 2

Issue Number: 03-14

**Subject Technical Information & Data**

Date: 03-10-14

Reference: JNA-032014

Dimensions in inches

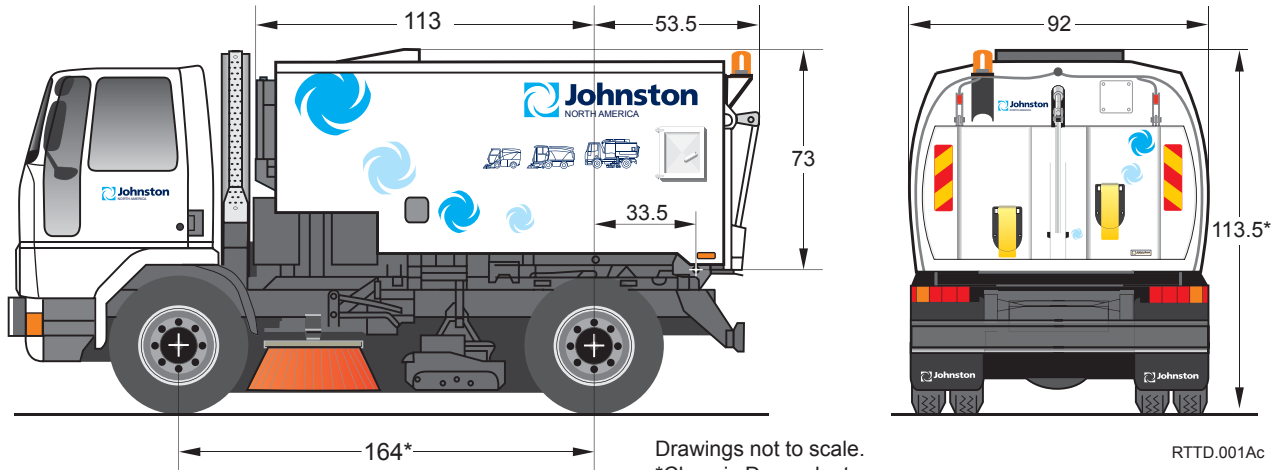

## Data and Performance Information

Capacities	
Hopper voided volume	8.5 yds <sup>3</sup>
Fuel tank	58 gallons
Water tank	253 gallons
Hydraulic system	20 gallons

Engine Data	
Model	John Deere 4045 HF285
Cubic capacity	275 in <sup>3</sup> (4.5 litres)
Gross rated power	115 hp @ 2200 rpm (86kW)
Maximum torque	387 lb/ft @ 1500 rpm (525Nm)
Legislation compliance	Tier 3 US EPA A Flex
Operational rpm	Variable between 1200-2000rpm
Sump capacity	2.5 gallons
Ambient temperature	120°F worldwide approval
Cold start capability	-4°C

Sweeping Equipment	
Channel brush (CB)	43 in; forward facing
CB life expectancy	80 accumulated working hours
Pick up hood width	93 in
Nozzle trunking diameter	Flexible Rubber Steel Reinforced
Pressure	14 in
Suction	14 in

General Data	
Chassis requirement	28,600-35,000 lbs
Wheelbase	164 in to 178 in chassis dependent
Dump height	39 in chassis dependent
Dump angle	55° nominal
Door opening angle	125° nominal
Filter mesh area	2500 square inches
Dust spray pump output	Up to 9.2 GPM.
Dust spray water pressure	50.75 PSI
Hydraulic suction filtration	125 micron
Hydraulic return filtration	25 micron
Hydraulic pump displacement	Max output 8.7 GPM
Sweeping speeds	1-10 mph chassis dependent

**Johnston North America Inc.**  
606 A&B Performance Road • Mooresville, NC 28115



# Technical Specification

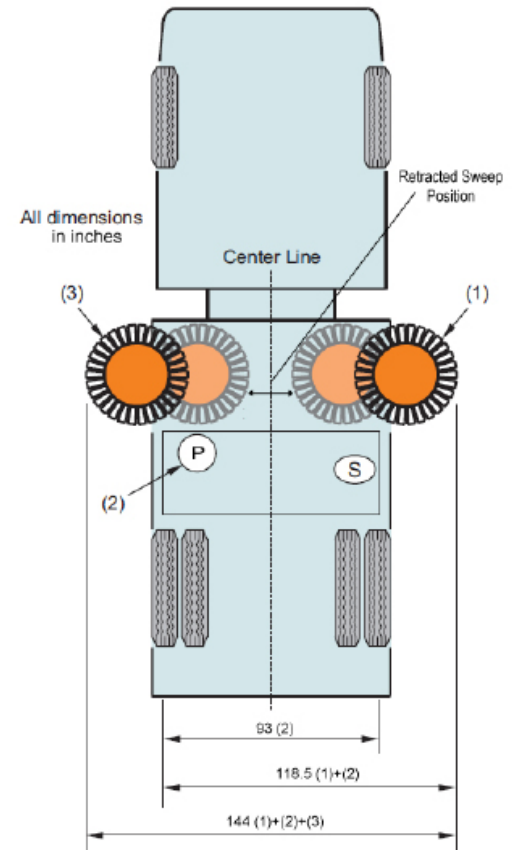
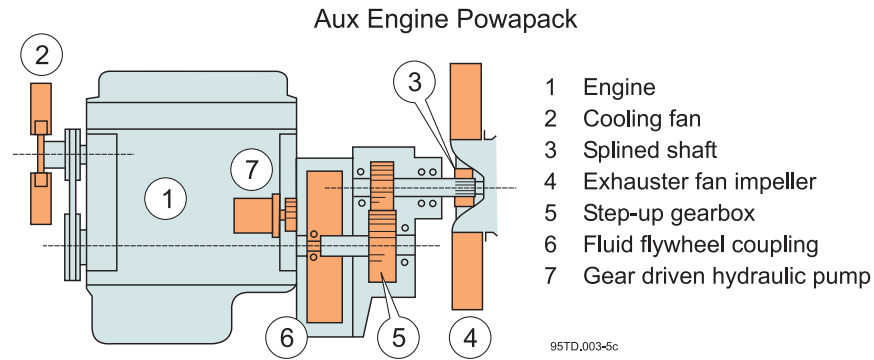

## Base specification

### Performance data

#### Fan system:

- Heavy Duty, stainless steel dynamically balanced impeller with backward-curved multi vane blades.
- Operational speed variable between 2400 RPM to 3500 RPM to easily adapt to application.
- Driven from the auxiliary engine via fluid coupler and step-up gearbox.
- Set-up Gearbox ratio – 1:1.79

#### Gutter broom:

- 43 inch forward facing, digger style configuration
- In-cab down pressure and variable speed controls (0-135 RPM).
- Sweep Position, fully extended or in front of pickup head.

#### Pick up head:

- 93 inch, forward and reverse debris pick-up Low noise suction system with 14 inch diameter suction and pressure hoses.
- In-Cab variable control vacuum enhancer
- 144 inch sweep path with (2) gutter brooms.

#### Dust suppression system:

- Dust Suppression water nozzles located in suction tube (2), gutter brooms (8), inside of hopper (2) and front mounted chassis spray bar (4).
- H.D.Twin diaphragm water pump driven hydraulically from a direct coupled motor; self-priming and able to run dry without damage.
- Water winterization purge system

#### Electrical system:

- All internal and external wiring conforms to IP65 and IP67 standards—waterproof and dustproof.
- 12 volt system is integrated with the truck chassis for easy troubleshooting.

#### Controls:

In-Cab mounted master switch panel housing sweep controls condition status indicator lamps, including:

- Raised hopper warning
- Auxiliary engine hour counter
- Equipment fuel gauge
- Low level lost water
- Engine tachograph meter
- Low level hydraulic oil indicator
- Recall sweep-sweep pause & resume
- Reverse auto sweep interrupt

#### In cab noise:

<60 dB(A)-generally dependent on chassis selection.

#### Exterior noise / Sound power level:

$L_{WA}$  110 dB(A) for turbocharged engine measured in accordance with EC directive 2000/14/EC.

#### Debris Body

- Comprises of 8.5 yard hopper and full auxiliary engine cowling. Fabricated from heavy duty 9 gauge stainless steel.
- Access doors fitted on both sides with safety grab handle and step to allow for screen and body load inspection.
- Separate polyethylene water tank incorporates anti-surge baffles and filled via water hydrant.

- Single lock rear door latching system with (2) de-watering drain ports.
- Hopper deluge and dust separator washout system.
- High visibility, automatic body tipping mechanism.
- Service ladder and platform.
- Hydrant layflat hose and stowage basket.

#### Optional equipment

- Camera monitoring system.
- Pneumatic hopper screen shakers.
- Rear mounted hydraulic power assisted 8 inch wanderhose
- Rotatilt In-Cab Gutter Broom Tilt
- Rotating/strobe beacons.
- Supawash - high pressure washing system
- 8.5 gallons/min @ 1500 PSI bar. Handlance, hose reel, Front high pressure spraybar optional.
- Gutter Broom Extension Override (GEO) allows operator to bring the gutter brooms in front of the pick-up head to remove heavy and compacted debris.
- Extra water tank capacity.

A comprehensive range of additional options is available. Please ask for details.